

3969872COM Tuxedo Beverage Cabinet

Ameriwood
HOME

Date of Purchase: ____/____/____
Lot Number:

B343969872COM00PK

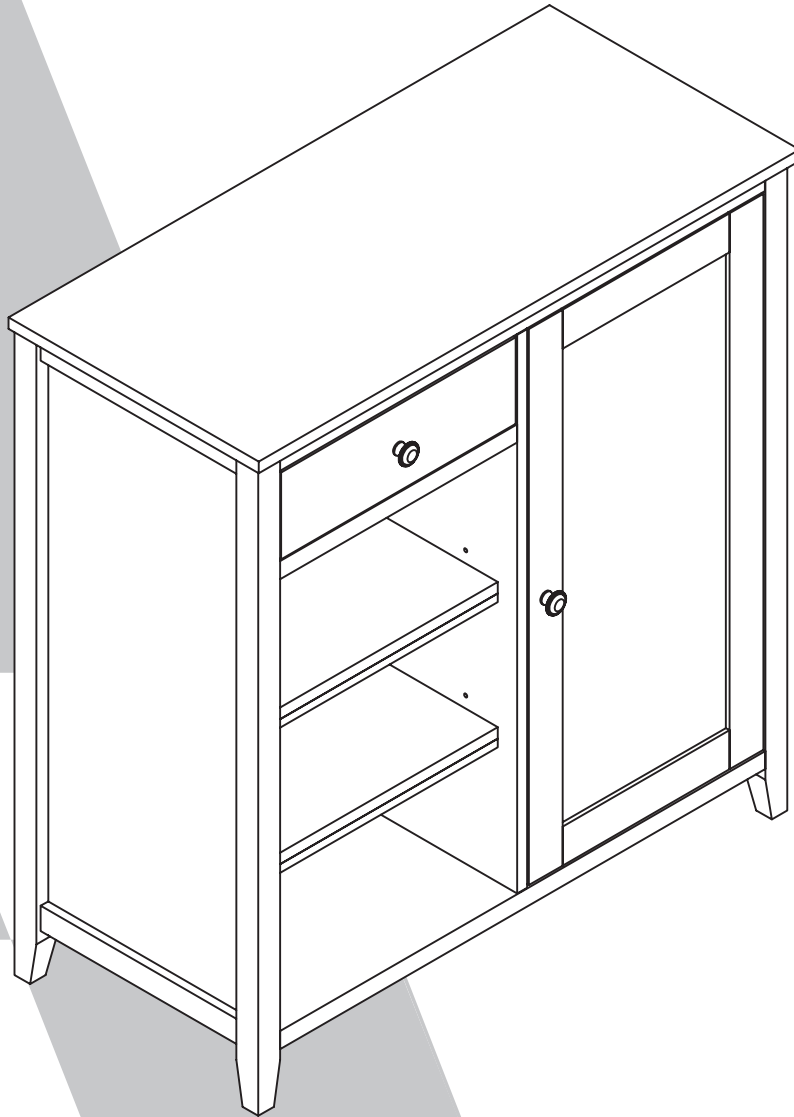

122020PK

THIS INSTRUCTION BOOKLET CONTAINS **IMPORTANT** SAFETY INFORMATION. PLEASE READ AND KEEP FOR FUTURE REFERENCE.

Do Not Return This Product!

Contact our customer service team for help first
Call: 1-800-489-3351 (toll free)
Monday-Friday 9am - 5pm CST
Visit: www.ameriwoodhome.com



WARNING

- Unit can tip over causing severe injury or death.
- Anchor unit to stud in wall (if instructed to)
- Do not allow children climb on unit
- Put heavy items on lower shelves or drawers



Follow Ameriwood Home



Contact Us!

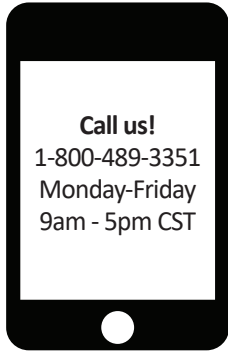

Do NOT return this product!
Contact our friendly customer service team first for help

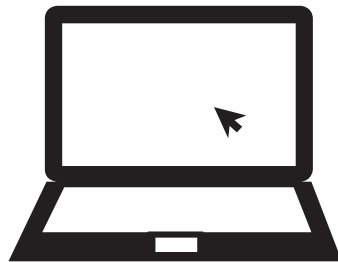

Visit ameriwoodhome.com

Assembly Tips



Helpful Hints

PEOPLE NEEDED FOR ASSEMBLY: **1-2**
ESTIMATED ASSEMBLY TIME: **30 MINUTES**

- Open your item in the area you plan to keep it for less heavy lifting
- Identify, sort and count the parts before attempting assembly
- Compression dowels are tapped in with a hammer
- Slides are labeled with a R (right) and L (left) for proper placement
- Make sure to always face the point on the top of the Cam Lock towards the outer edge
- Use all the nails provided for the back panel and spread them out equally
- Back Panel must be used to make sure your unit is sturdy
- Do NOT use harsh chemicals or abrasive cleaners on this item
- Never push, pull, or drag your furniture



Before You Start

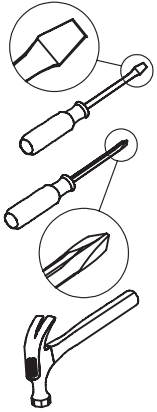
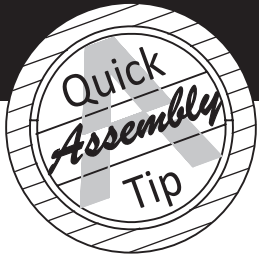

- ✓ Read through each step carefully and follow the proper order
- ✓ Separate and count all your parts and hardware
- ✓ Give yourself enough room for the assembly process
- ✓ Have the following tools: Flat Head Screwdriver, #2 Phillips Head Screwdriver and Hammer
- ✓ Caution: If using a power drill or power screwdriver for screwing, please be aware to slow down and stop when screw is tight. Failure to do so may result in stripping the screw.

Cam Lock Fastening System

This Cam Lock Fastening System will be used throughout the assembly process.

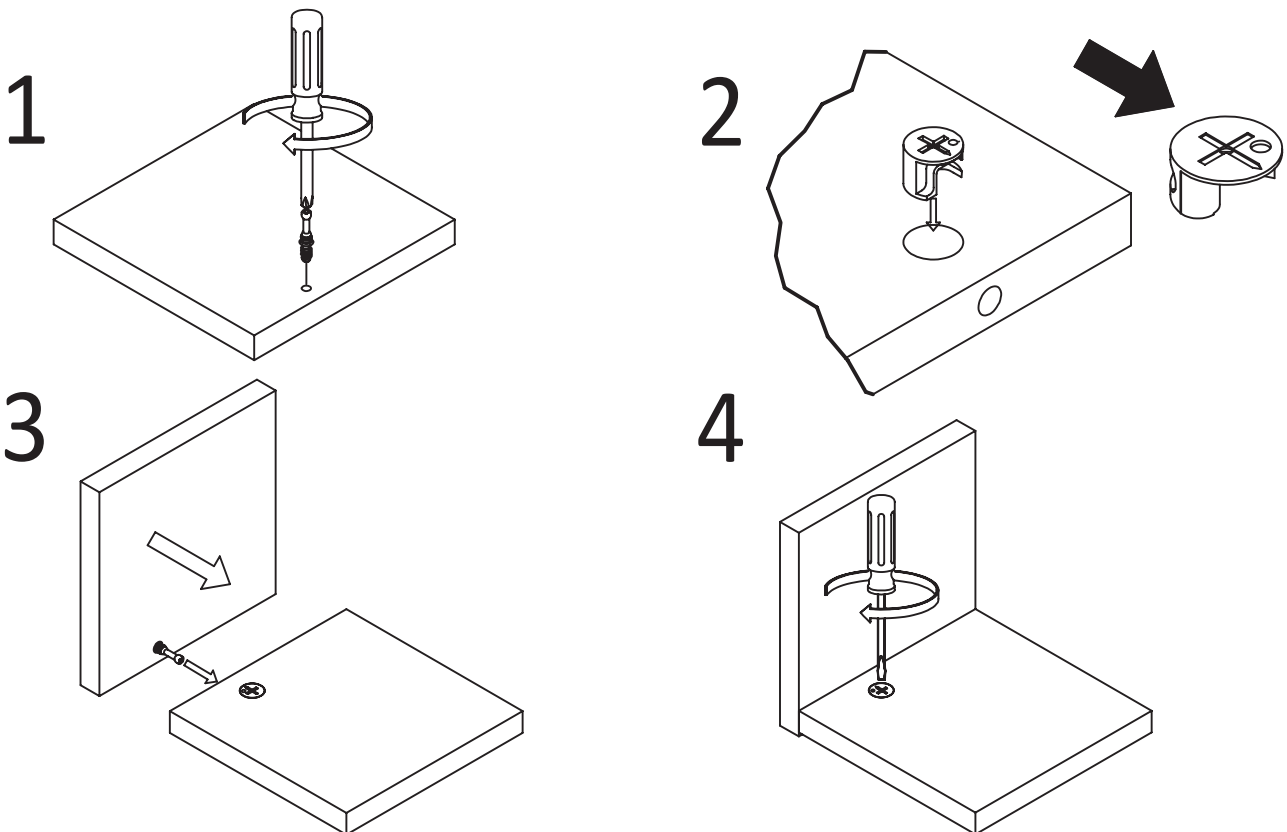

Board Identification

Not actual size

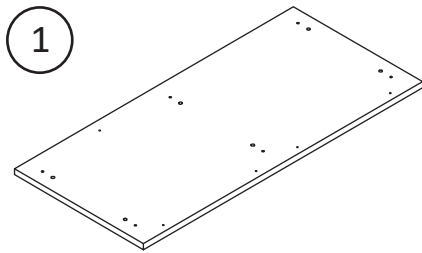

x1
T3969872010PK
TOP PANEL

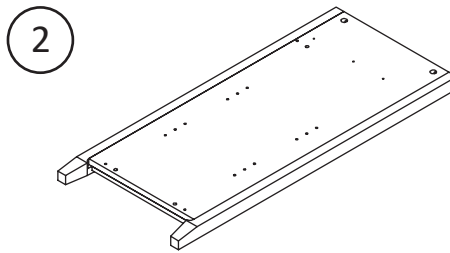

x1
T3969872020PK
LEFT SIDE PANEL

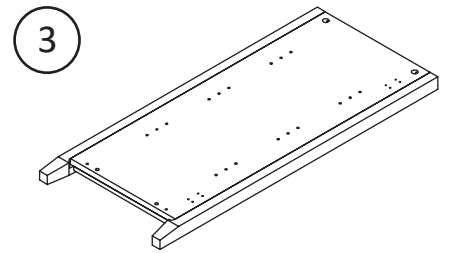

x1
T3969872030PK
RIGHT SIDE PANEL

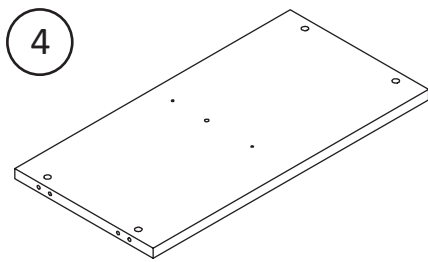

x1
T3969872040PK
BOTTOM PANEL

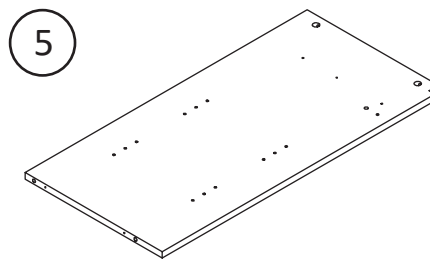

x1
T3969872050PK
PARTITION

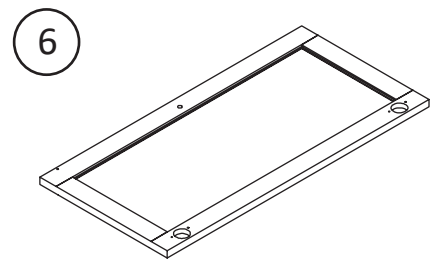

x1
T3969872060PK
DOOR PANEL

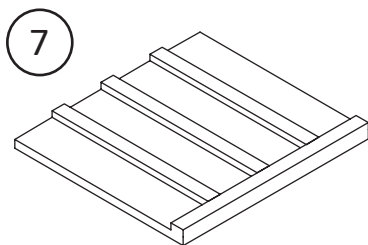

x5
T3969872070PK
ADJUSTABLE SHELF

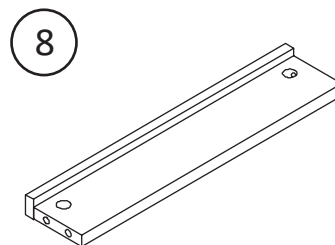

x1
T3969872080PK
BRACE

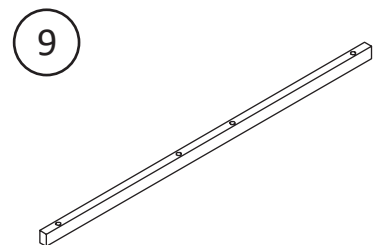

x1
T3969872090PK
TOP RAIL

Board Identification

Not actual size

10

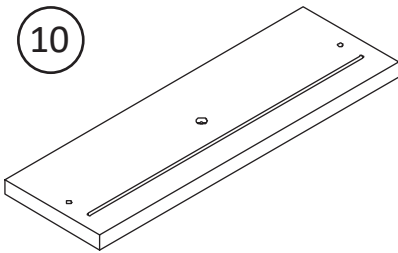

x1
T3969872100PK
DRAWER FACE

11

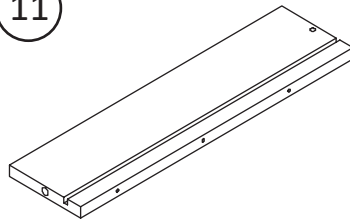

x1
T3969872110PK
LEFT DRAWER SIDE

12

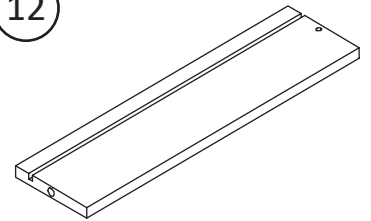

x1
T3969872120PK
RIGHT DRAWER SIDE

13

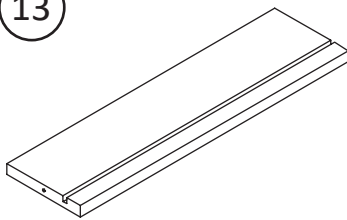

x1
T3969872130PK
DRAWER BACK

14

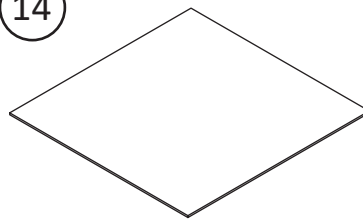

x1
T3969872140PK
DRAWER BOTTOM

15

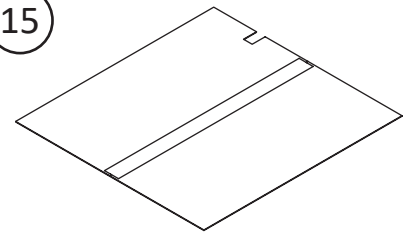

x1
T3969872150PK
BACK PANEL

16

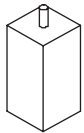

x1
T3969872160PK
CENTER LEG

Part List

Actual Size



x14
TPK0001
Cam Bolt

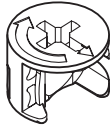

x14
TPK0003
Cam Lock 15-9



x14
TPK0004
DOWEL 8 X 30



x20
TPK0006
SHELF HOLDER



x27
TPK0007
CBS 3.5 x 16

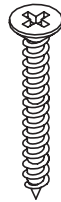

x6
TPK0019
CBS 4 x 30

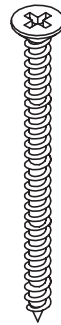

x2
TPK0022
CBS 4 x 50



x20
TPK0015
NAIL

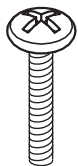

x1
TPK3011
HANDLE SCREW

Part List

Not Actual Size

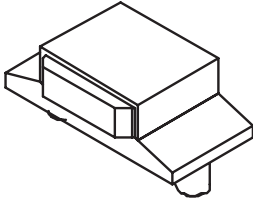

x1 Set
TPK0016
MAGNET

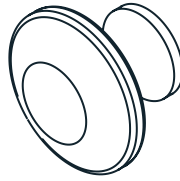

x1
TPK3010
HANDLE

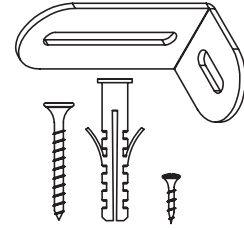

x1
TPK2004
ANTI TIPPING KIT

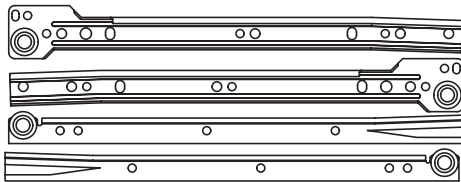

x1
TPK1001
DRAWER SLIDE 300MM

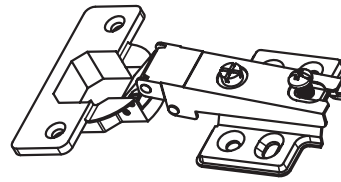

x2
TPK4001
DOOR HINGES

Step 1

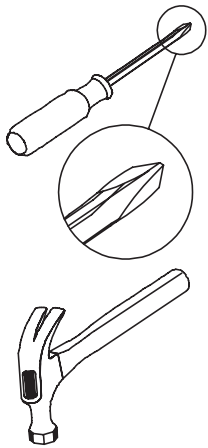

x5
TPK0001

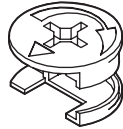

x4
TPK0003



x4
TPK0004

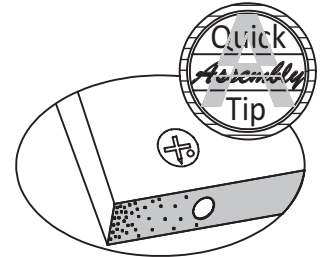
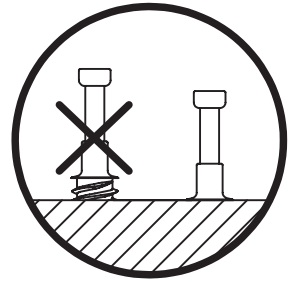

Proper orientation of CAM LOCK

Properly insert Cam Lock and dowel.

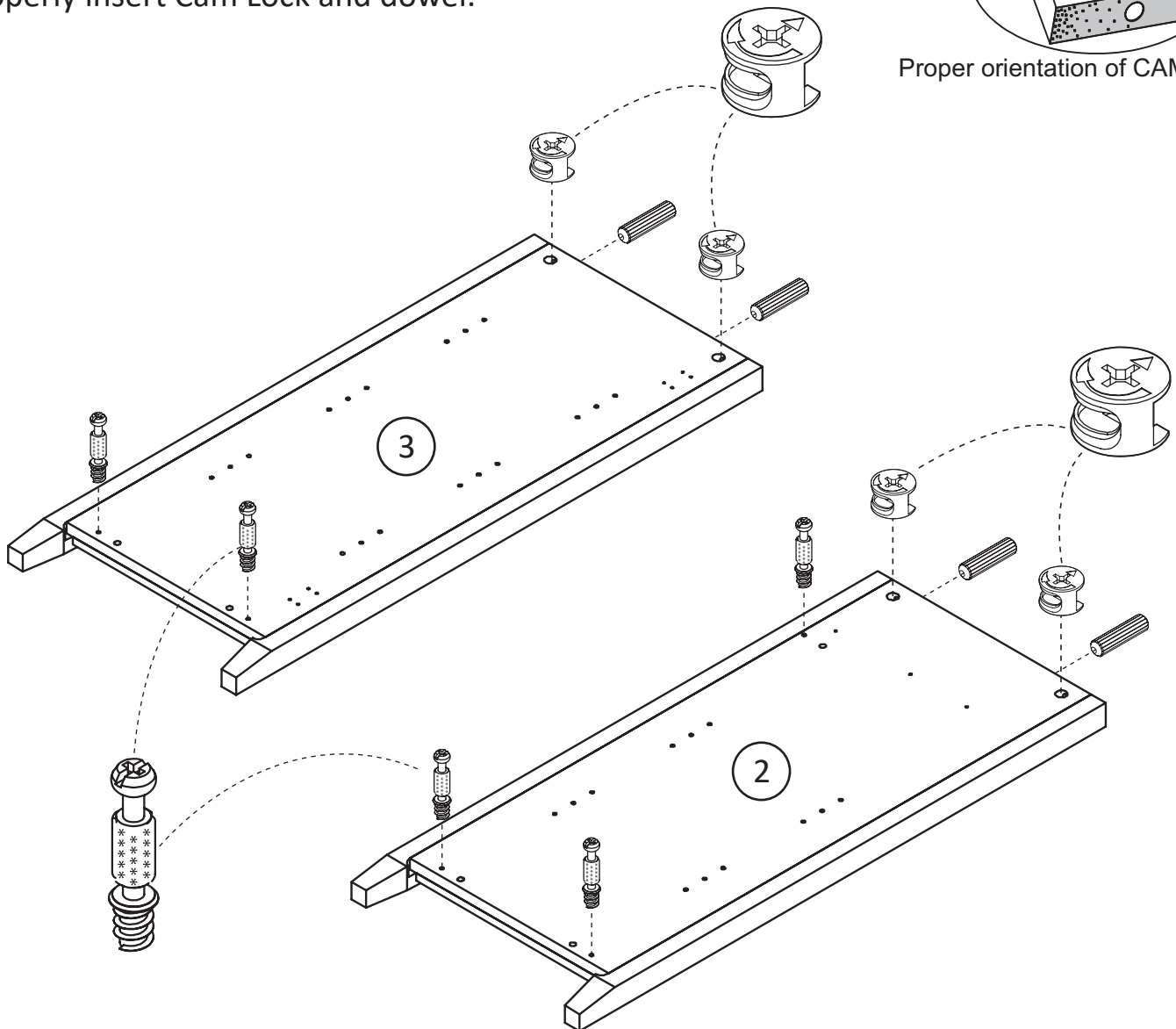

Step 2

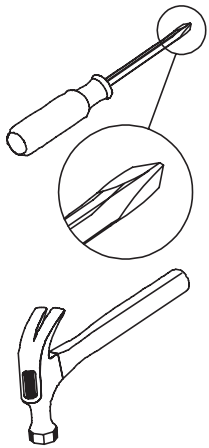

x1
TPK0001

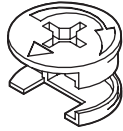

x2
TPK0003



x4
TPK0004

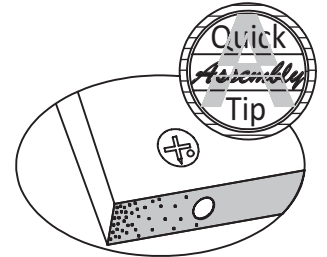
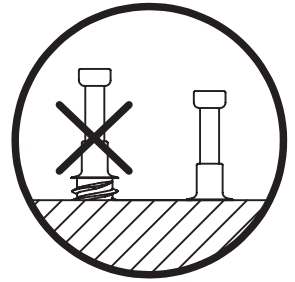

Properly insert Cam Lock and dowel.

Proper orientation of CAM LOCK

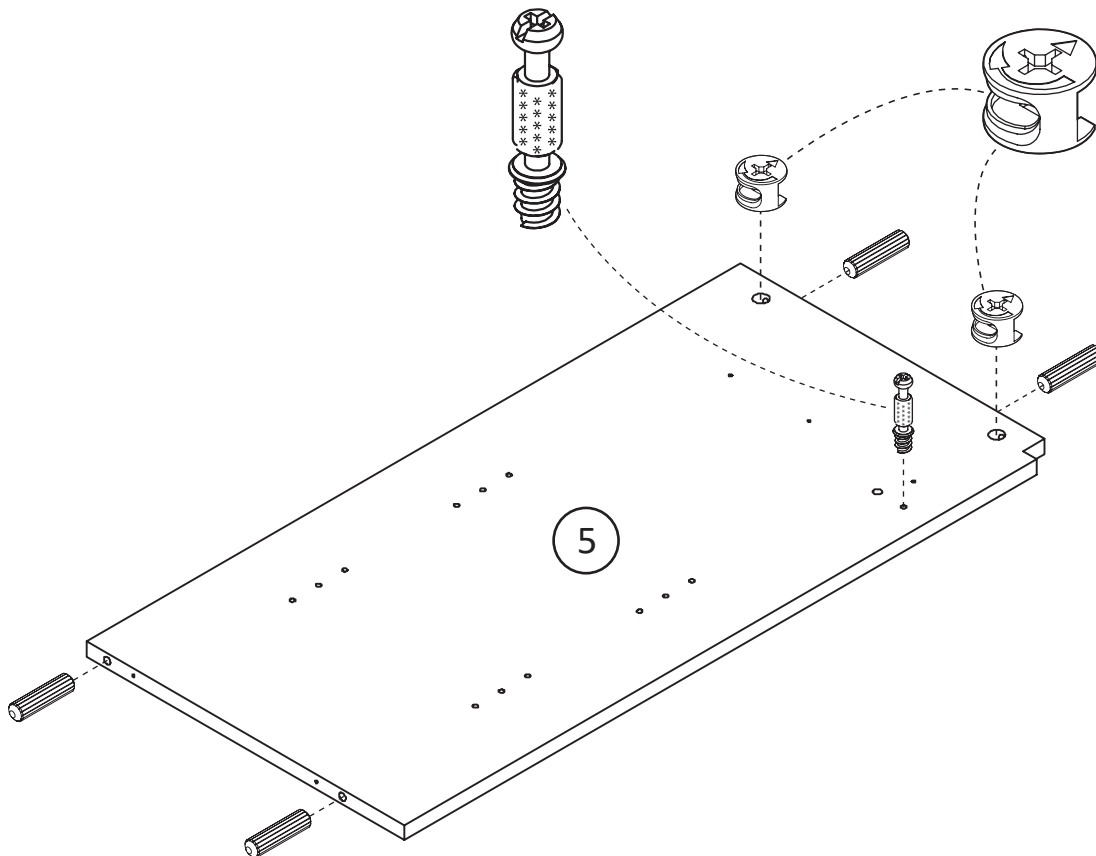

Step 3

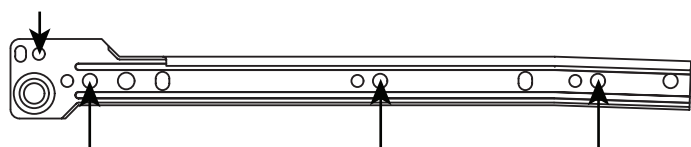
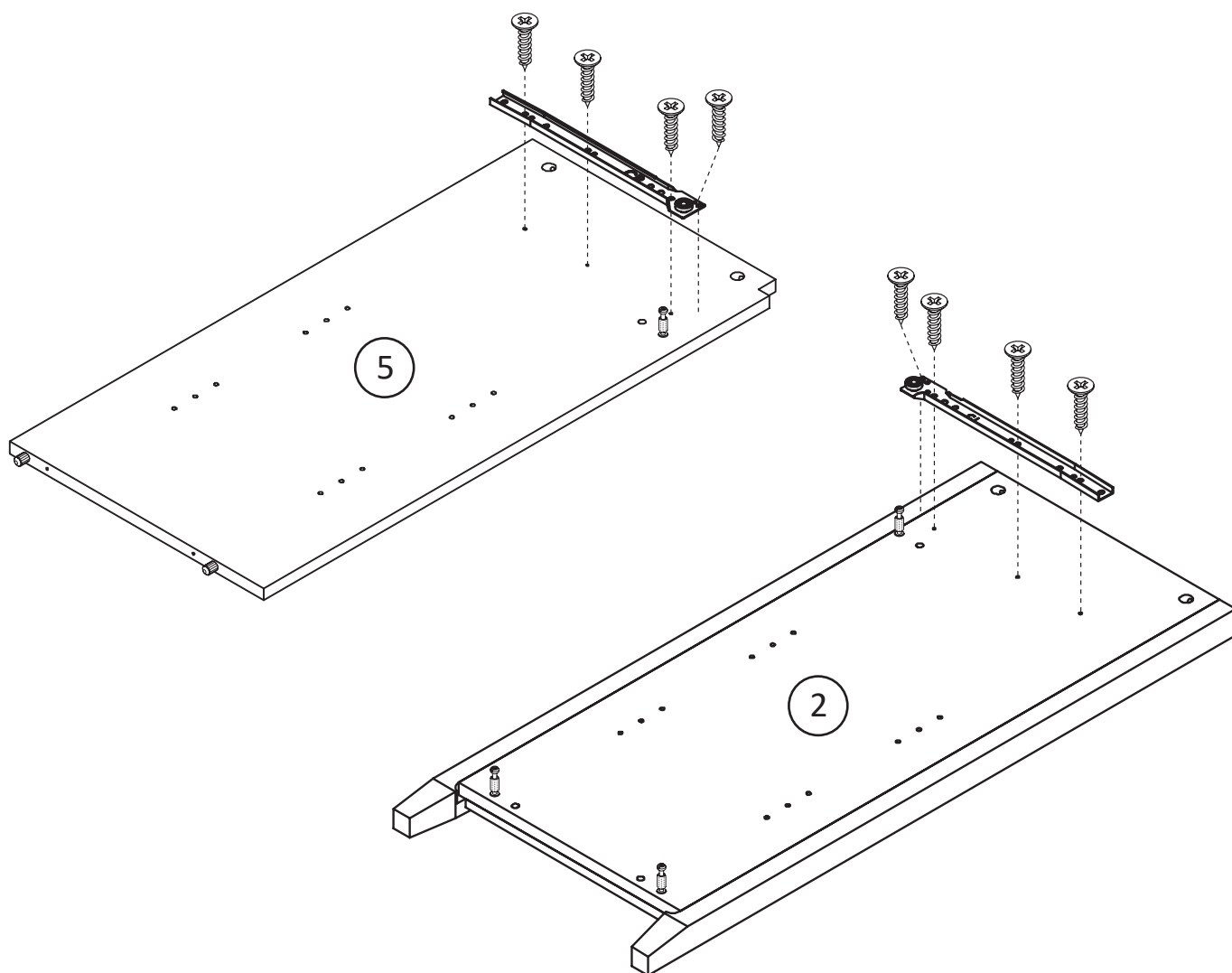
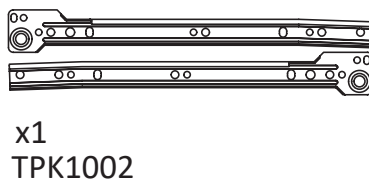
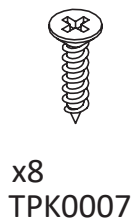
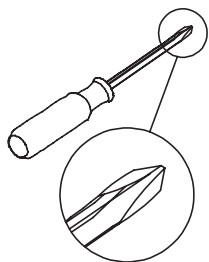

Slide (CL), screw position on panel number 2.

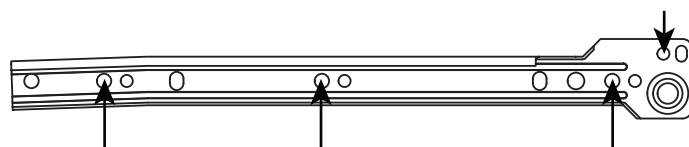

Slide (CR), screw position on panel number 5.

Step 4

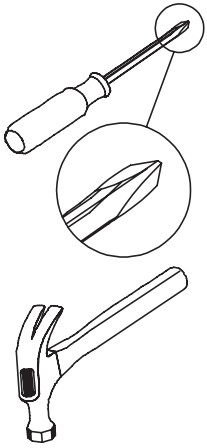

x6
TPK0001

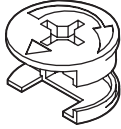

x6
TPK0003

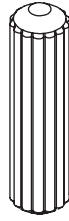

x6
TPK0004

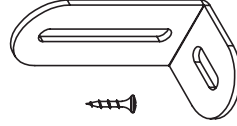

x1
TPK2004

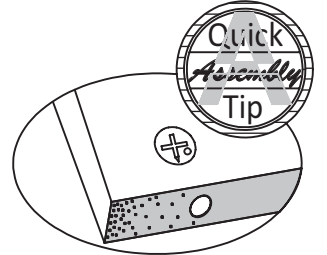
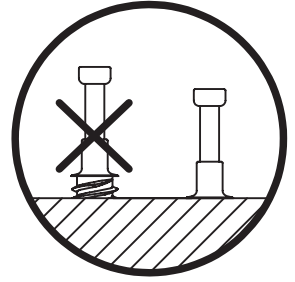

Proper orientation of CAM LOCK

Properly insert Cam Lock and dowel.

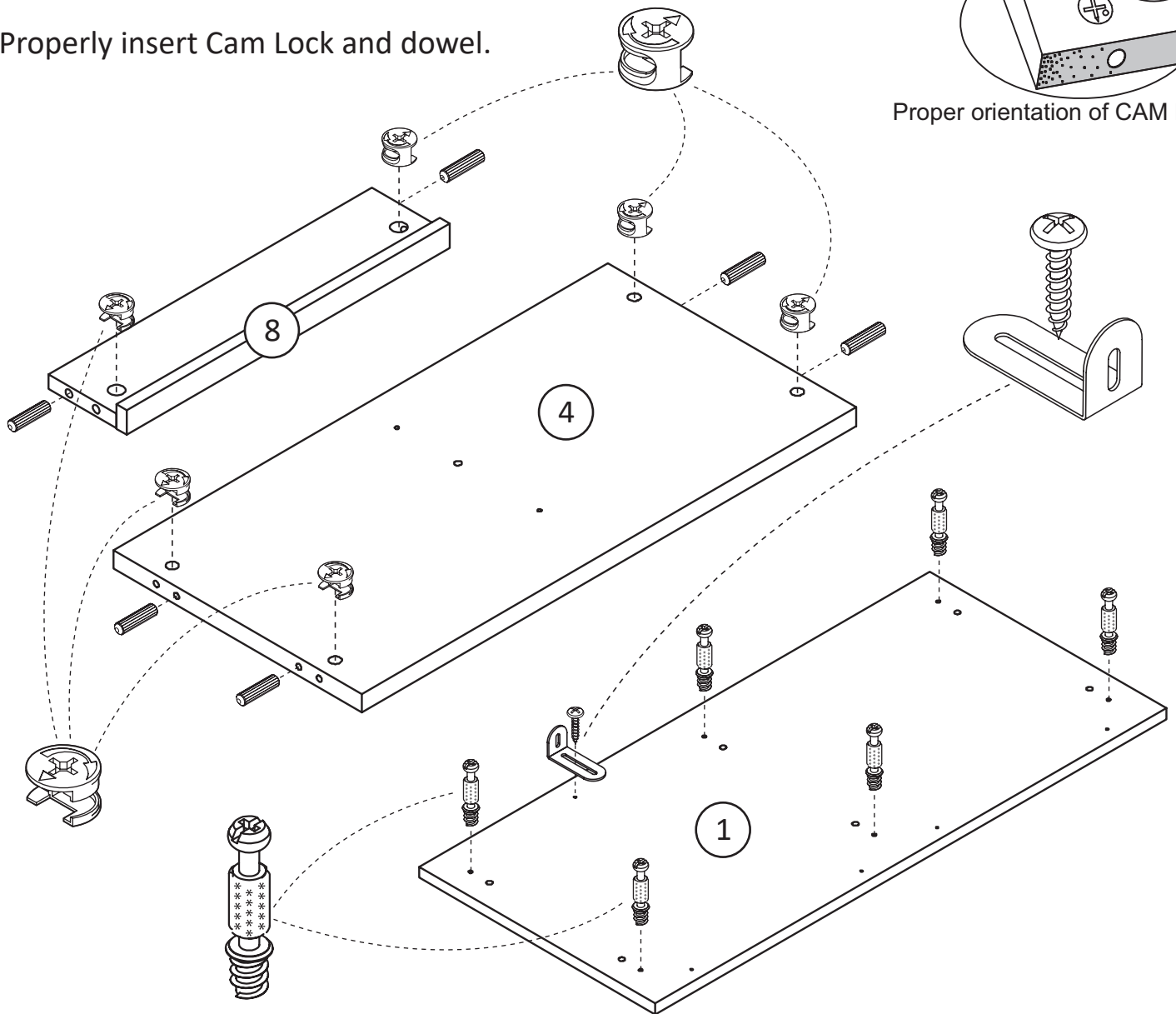

Step 5

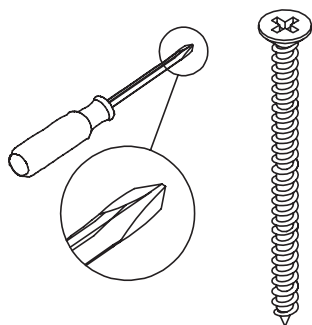

x2
TPK0022

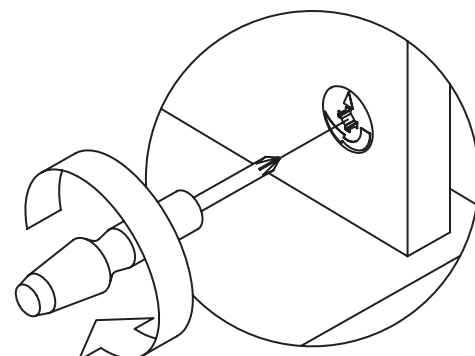

Attach panel 5 to panel 4. Then fully tighten the cam lock.

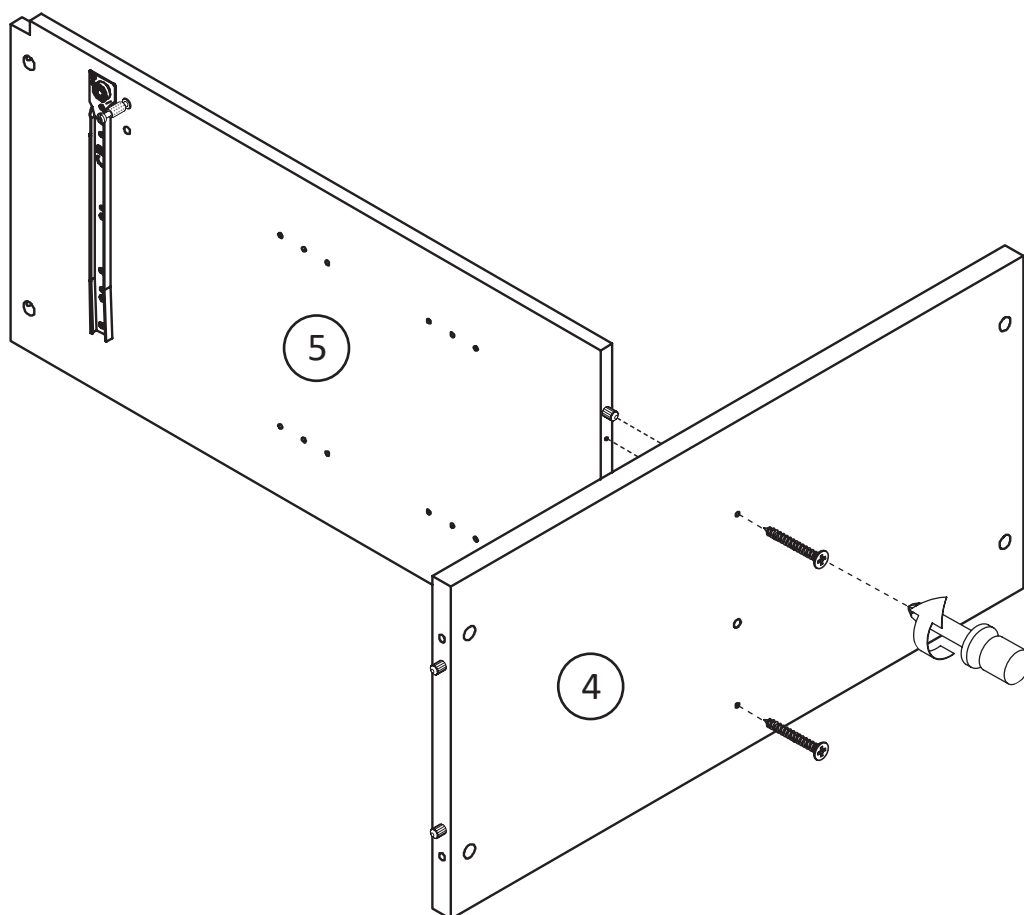

Step 6

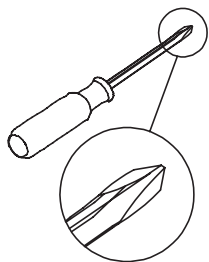

Next, attach panel 8 to panel 5 as shown. Make sure edge with profile facing upwards. Then fully tighten the panel 8's cam lock.

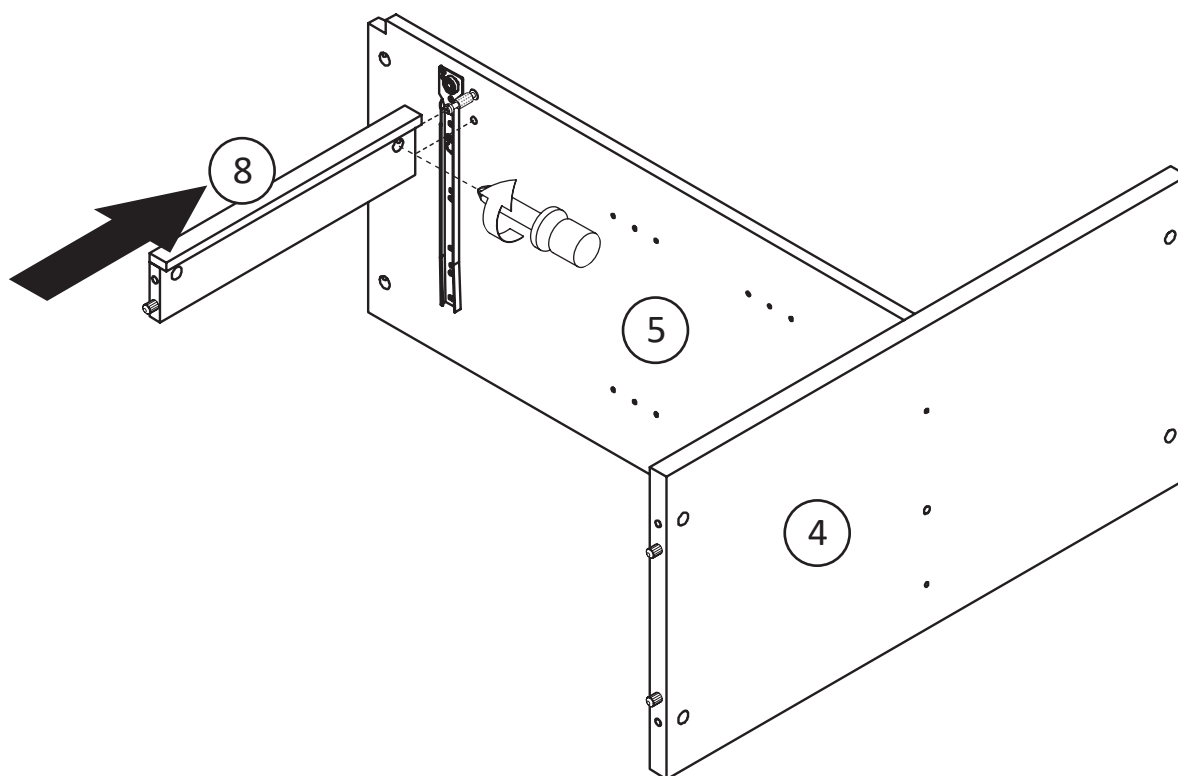
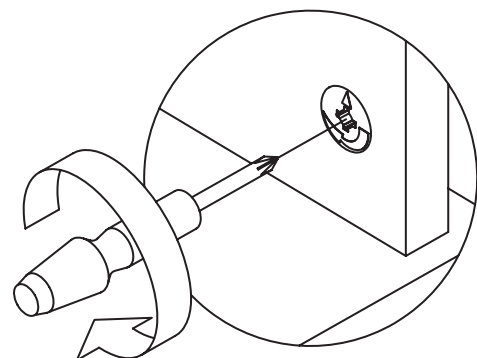

Step 7

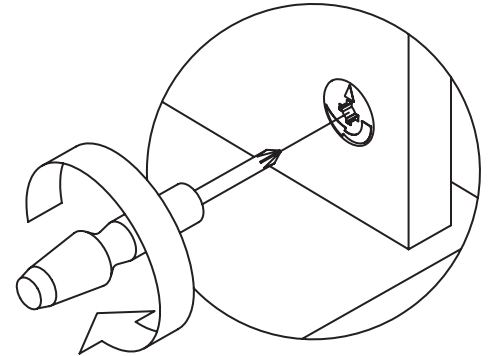
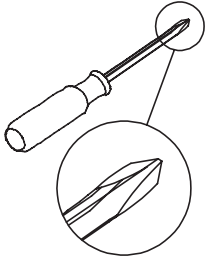

Attach panel 2 and panel 3 as shown.
Fix using screw as shown.

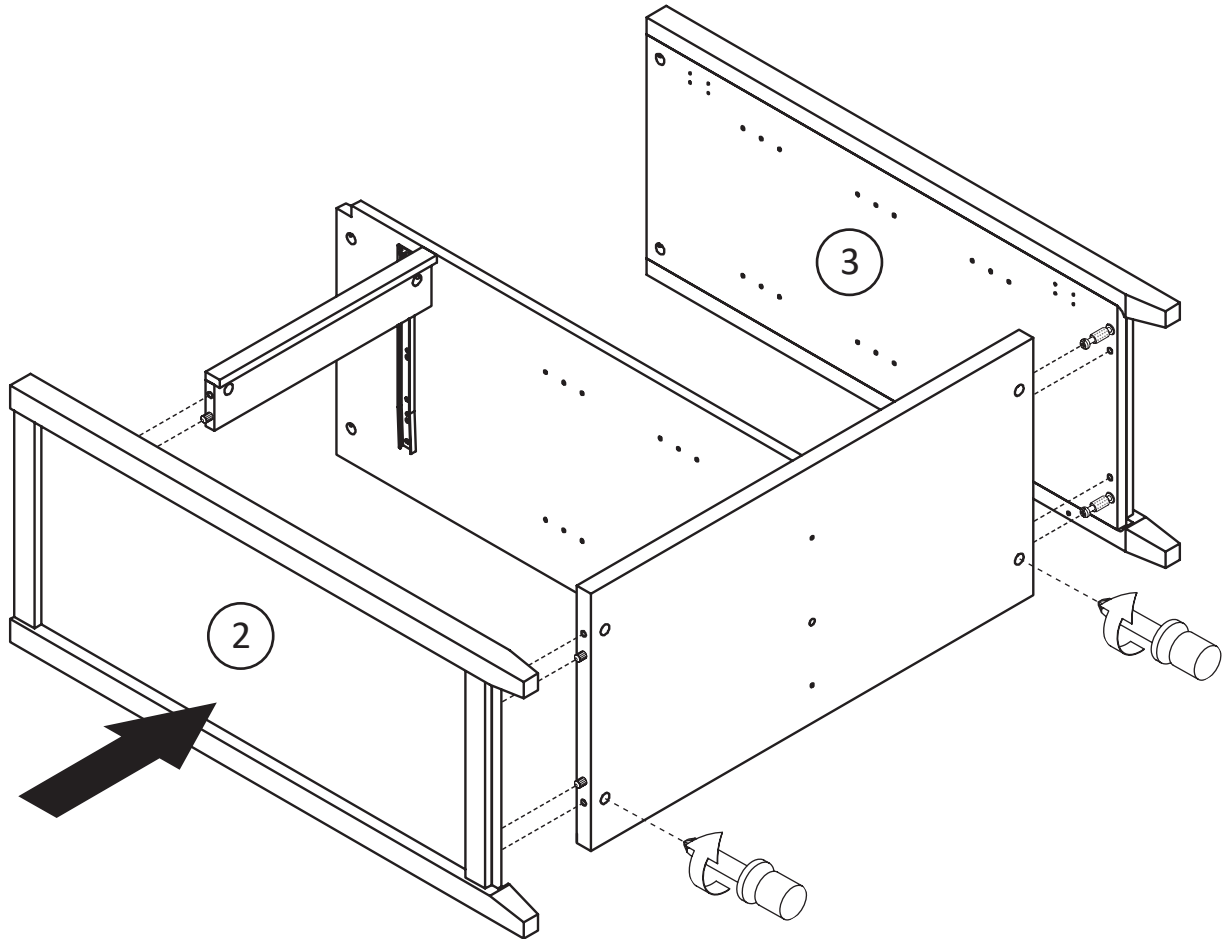

Step 8

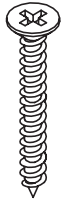
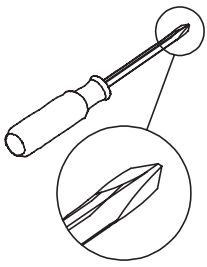

x4
TPK0019

Attach panel 9 to panel 1 as shown.
Fix using screw as shown.

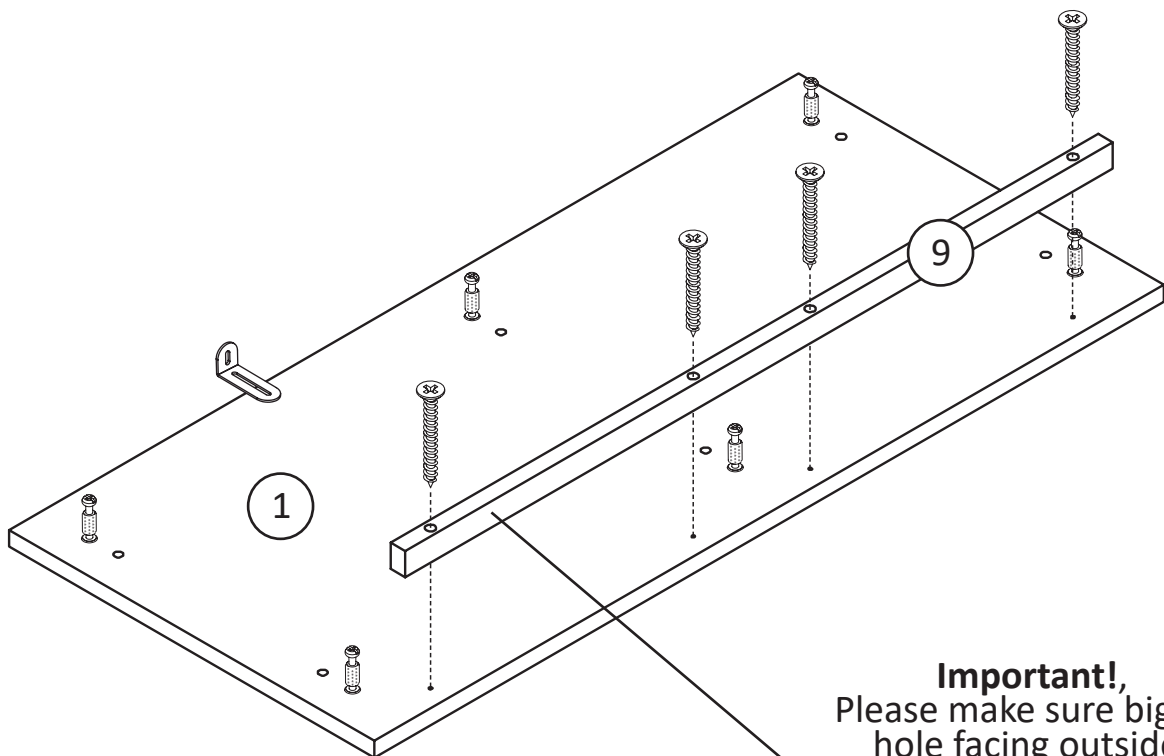

Important!
Please make sure bigger
hole facing outside.

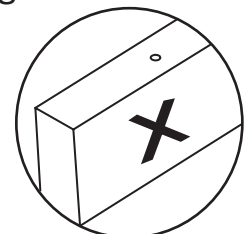
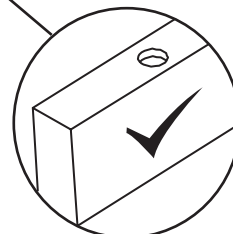

Step 9

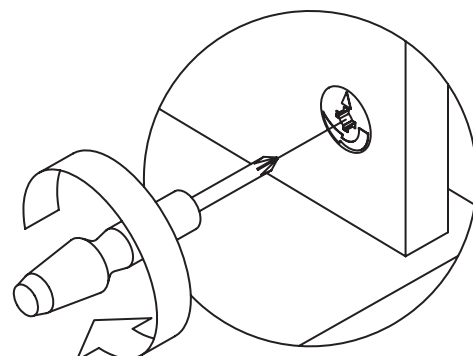
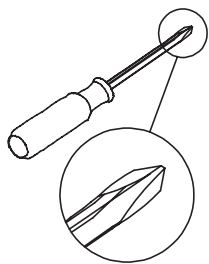

Next, attach panel 1 as shown. Make sure edge with profile facing upwards. Fix using screw as shown.

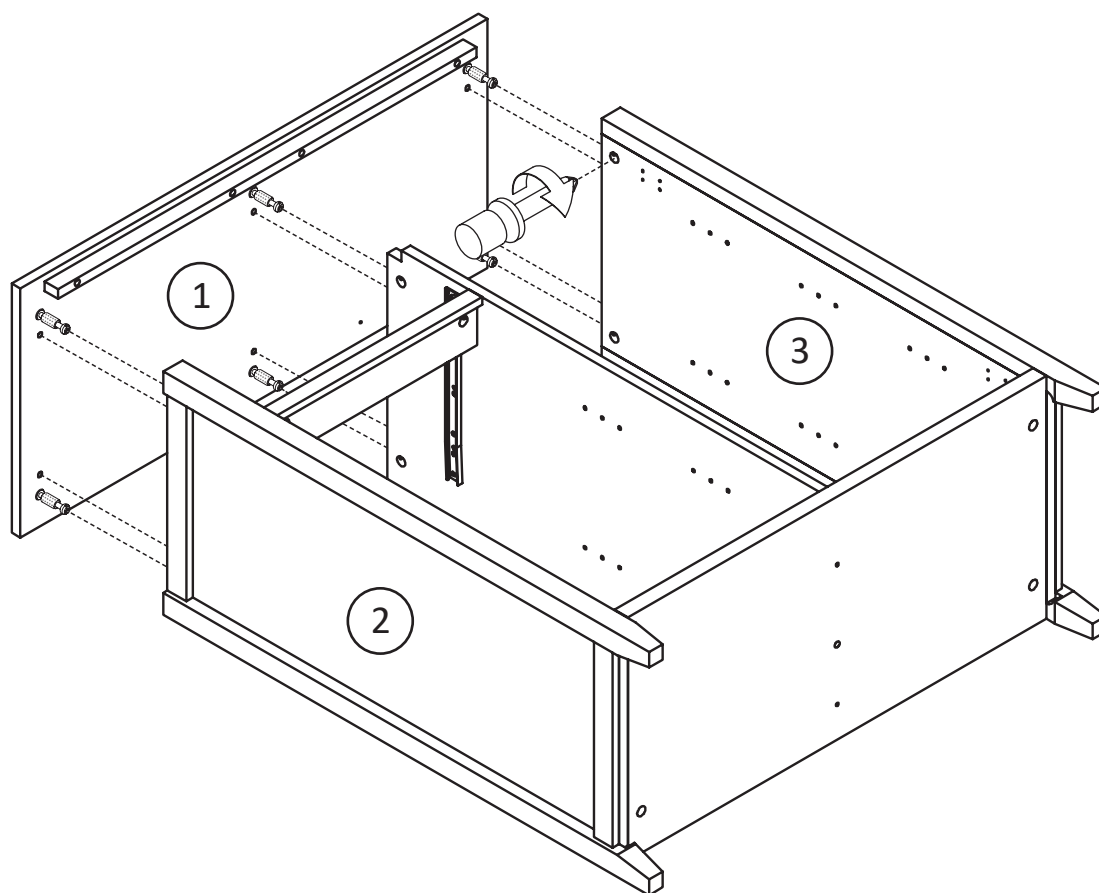

Step 10

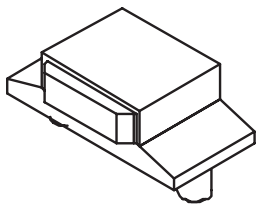
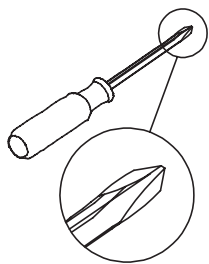

x1
TPK0008

Next, attach center leg to panel 4 as shown.

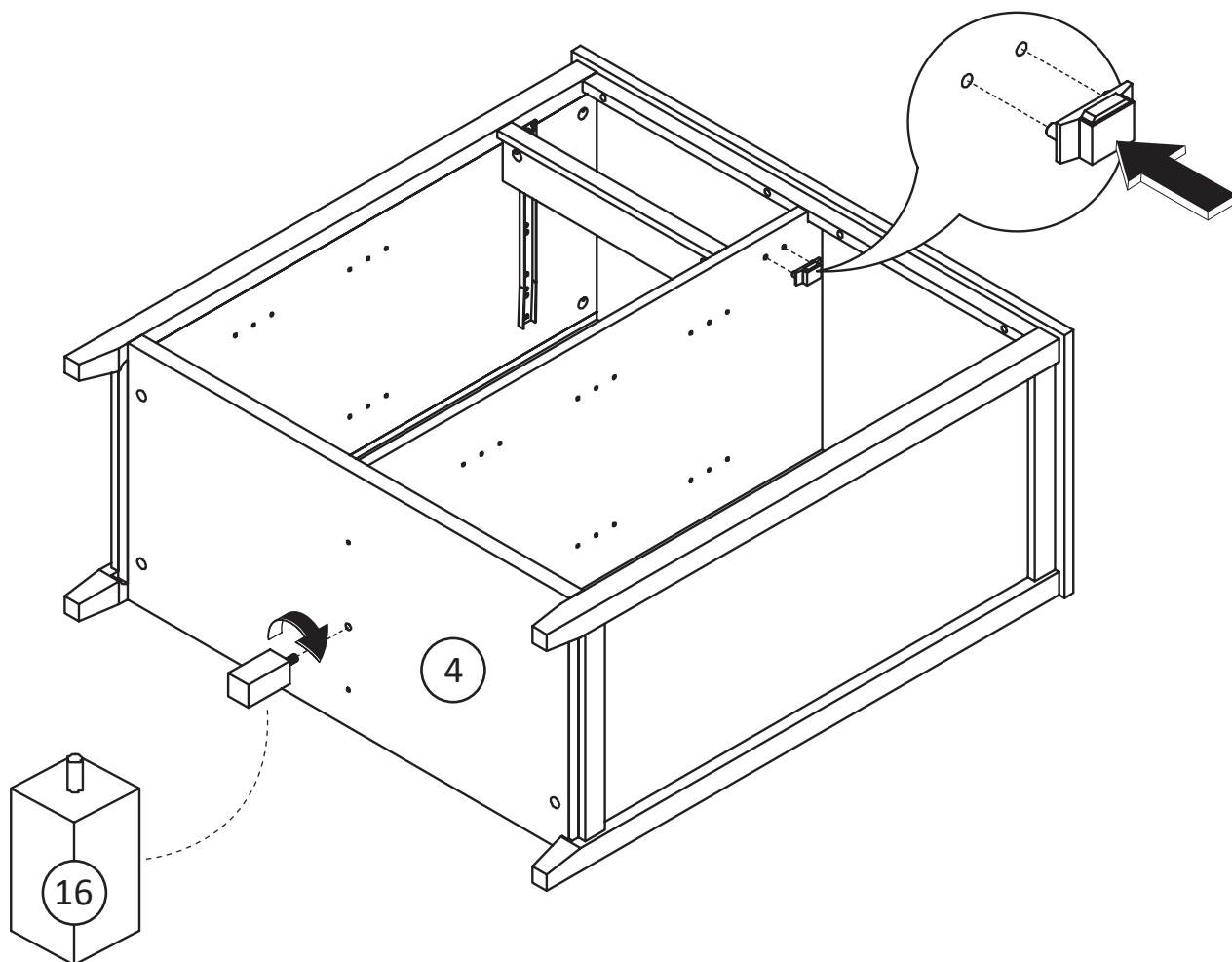

Step 11

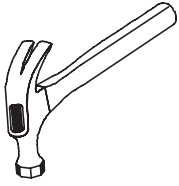

x20
TPK0015

Before attach panel 15, make sure to turn the carcass upside down. Be careful, the floor must clean and spread with soft cloth.

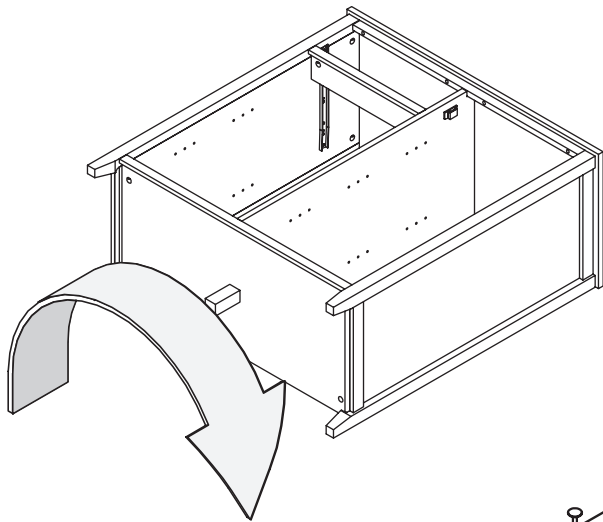

Attach panel 15, this panel is part of construction stability. Please ensure corner to corner in same dimension. Spread evenly the iron nails.

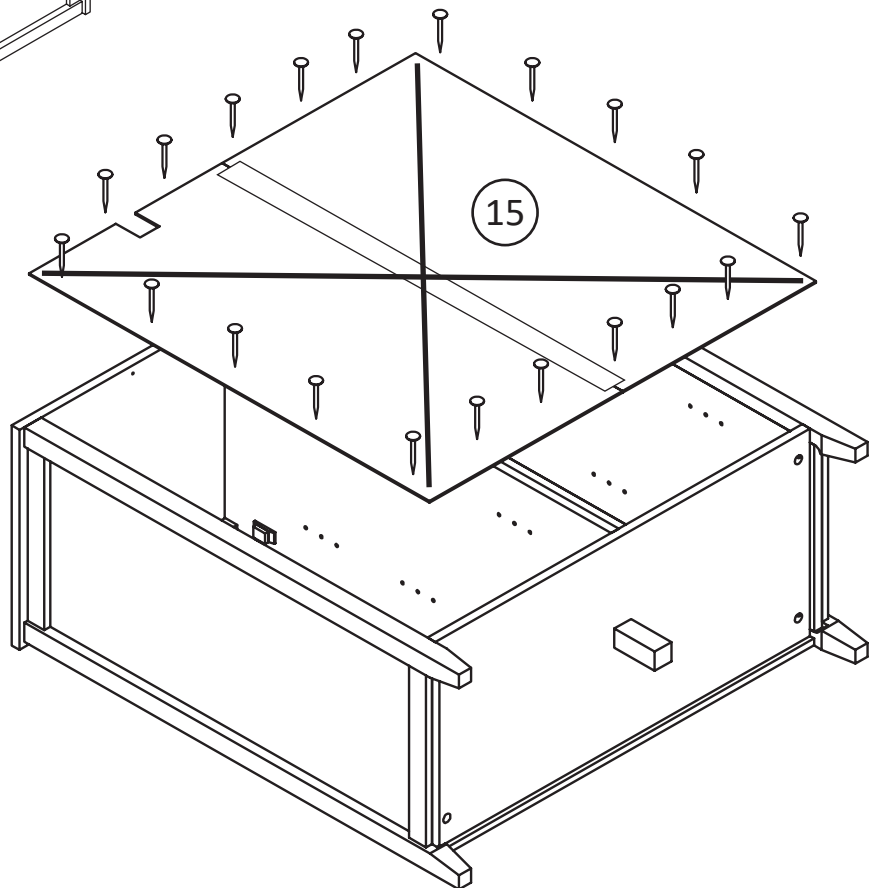

Step 12

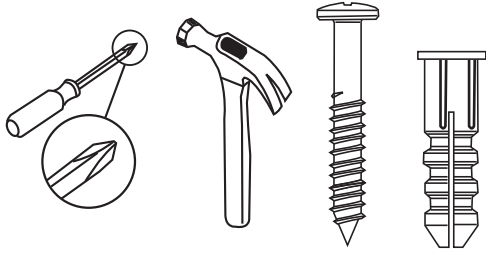

For Masonry, Concrete, or other wall materials:
Consult your local hardware store for appropriate anchors to securely attach the safety bracket.

IMPORTANT: THIS UNIT MUST BE SECURE TO THE WALL TO HELP PREVENT TIPOVER. FOLLOW THESE INSTRUCTIONS TO INSTALL THE ANTI-TIPPING SAFETY BRACKET PROVIDED WITH THIS PRODUCT.

WARNING

Serious or fatal crushing injuries can occur from furniture tipover.

To prevent tipover:

- * Install tipover restraint provided
- * place heaviest items in the lowest drawers
- * Unless specifically designed to accommodate, do not set TVs or other heavy objects on the top of this product
- * Never allow children to climb or hang on drawers, door, or shelves
- * Never open more than one drawer at a time

Use of tipover restraints may only reduce, but not eliminate the risk of tipover

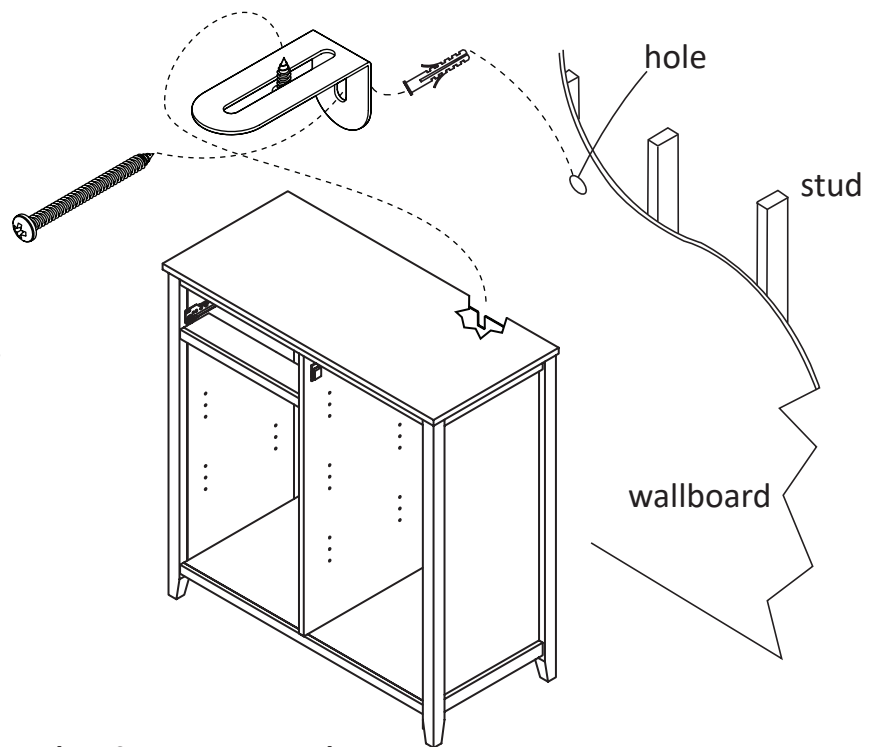

OPTION 1: Attachment into a wall stud (preferred method)

Using a stud finder, locate a stud in the wall. Place your unit against the wall, with the safety bracket aligned in this location.

To make driving the screw easier, you can drill a 1/8" diameter pilot hole (3mm) through the safety bracket into the stud.

Drive the screw through the safety bracket into the wall stud. Tighten the screw that was not fully tightened in step 5.

OPTION 2: Attachment into drywall

Locate your unit where desired against a wall and mark the wall through the safety bracket, then move your unit aside.

Drill a 3/16" diameter hole (5mm) into the wallboard. Tap the wall anchor into the hole until it is flush. Move your unit into location and fasten the wall bracket to the wall anchor with the screw.

Tighten the screw that was not fully tightened in step 5.

Step 13

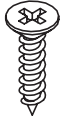
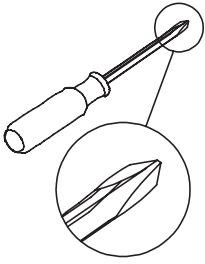

x5
TPK0007

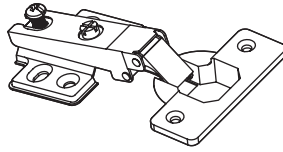

x2
TPK4001

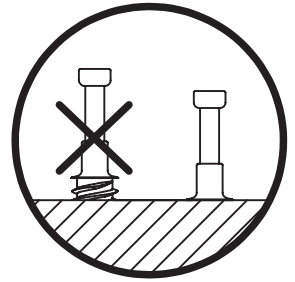

Attach door hinges to the door panel. Align carefully the hinges and make sure side faces parallel with door edge. Fully tighten the screws.

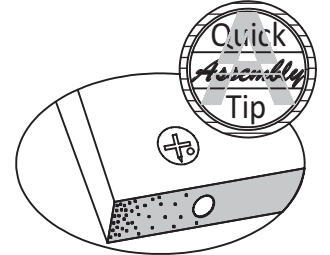

Proper orientation of CAM LOCK

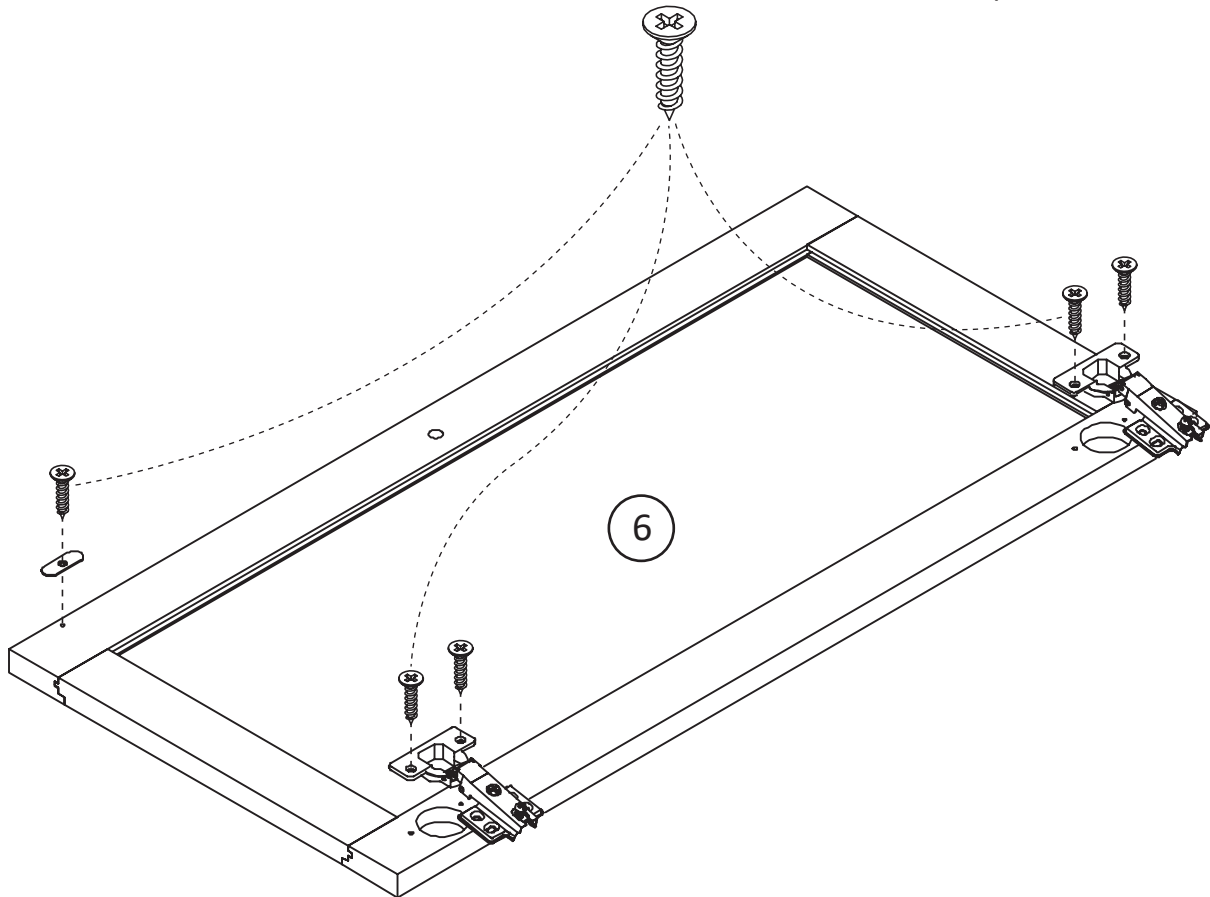

Step 14

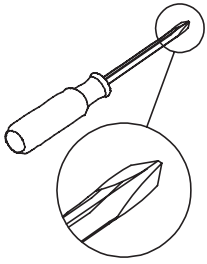

x8
TPK0007

Insert door to the side panel as shown below.

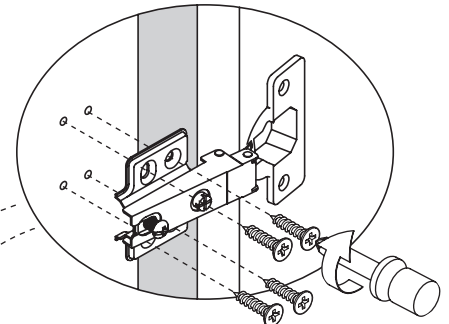
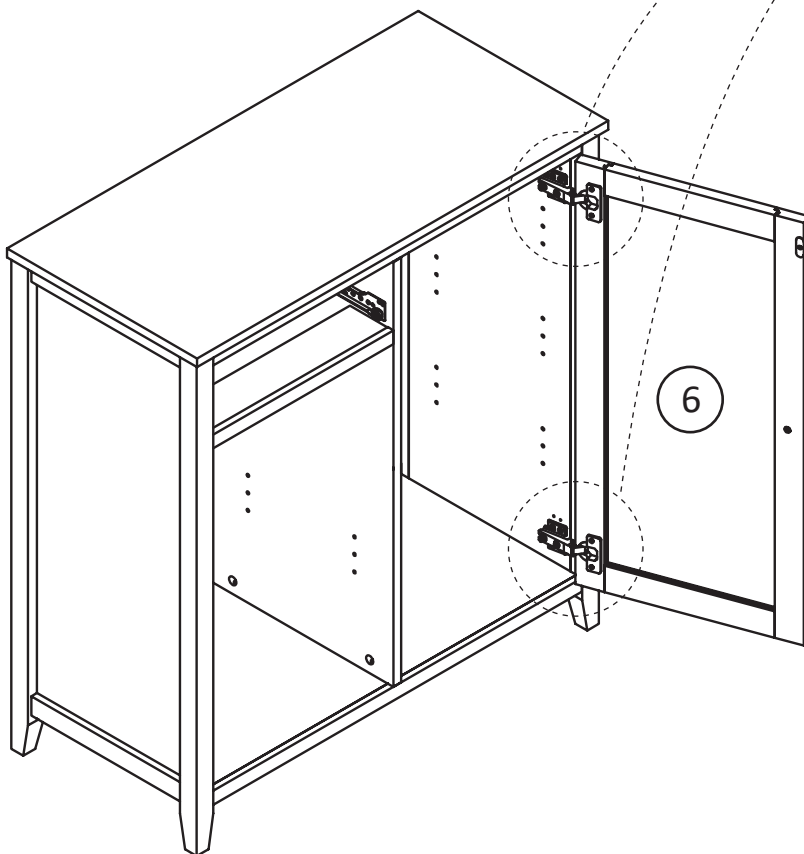

First, insert screw to the side panel.

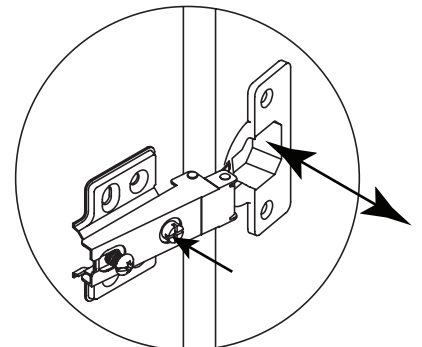

To adjust outside level, turn this screw, clockwise to move in, counter clockwise to move out.

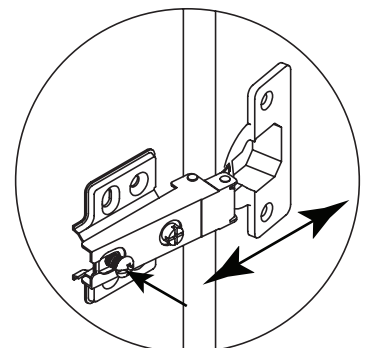

Loosen this screw to move door front or back, fully tighten this screw after finish make adjustment.

Step 15

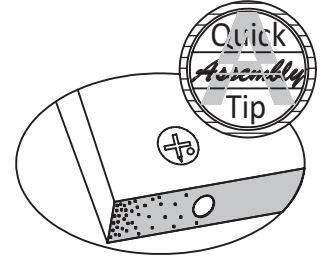
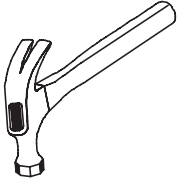
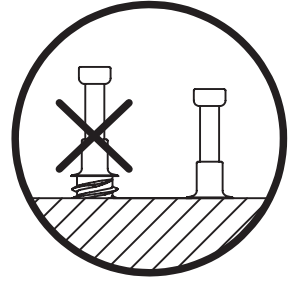
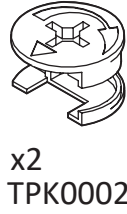
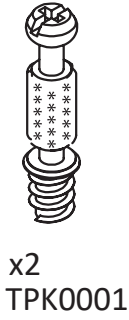
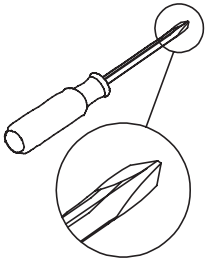

Properly insert Cam Lock.

Proper orientation of CAM LOCK

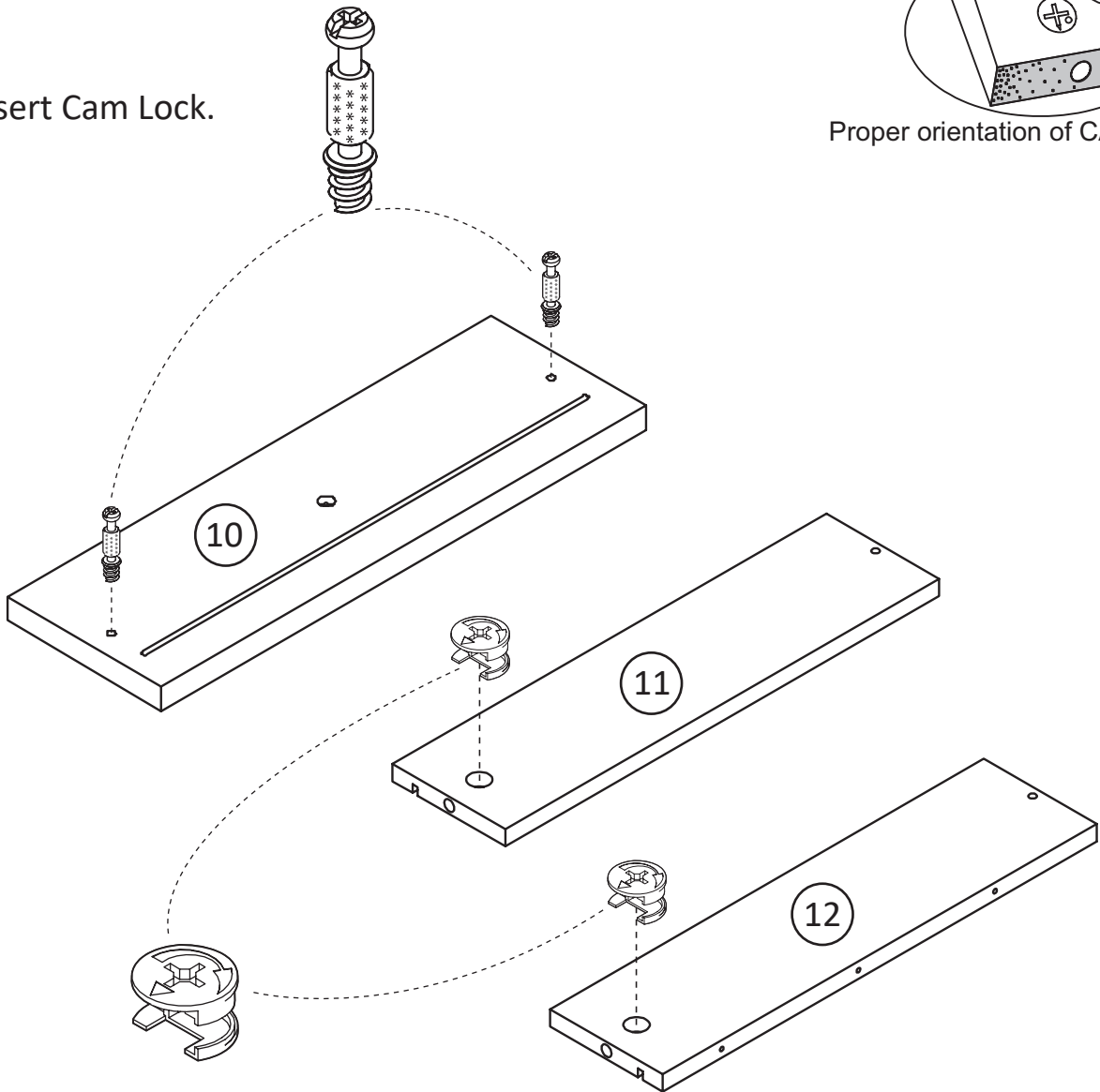

Step 16

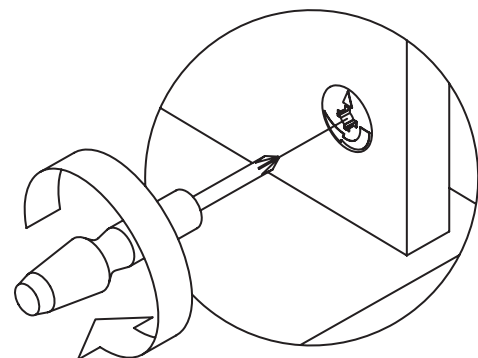
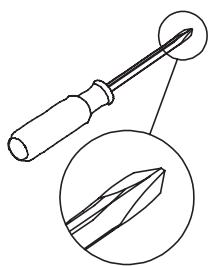

Attach panel 11 and panel 12 to the panel 10.
Fully tighten the cam lock.

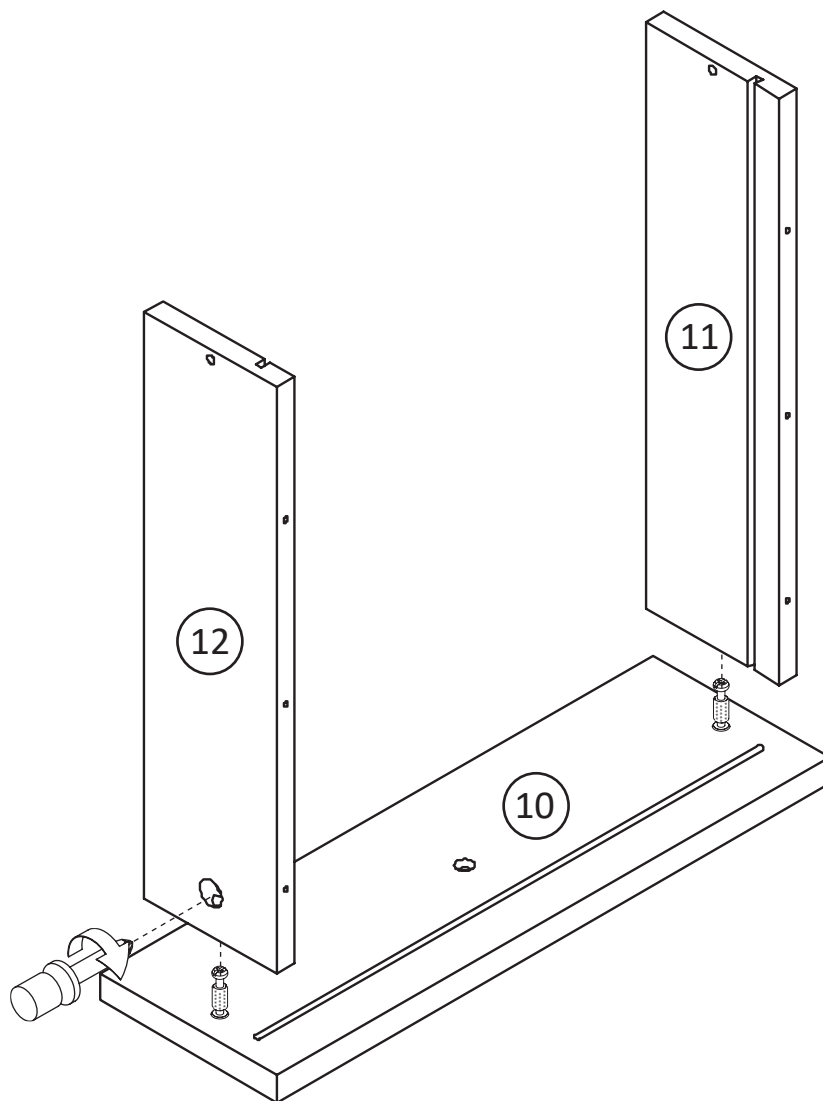

Step 17

Attach panel 14 by slot into groove on panel 11 & 12.

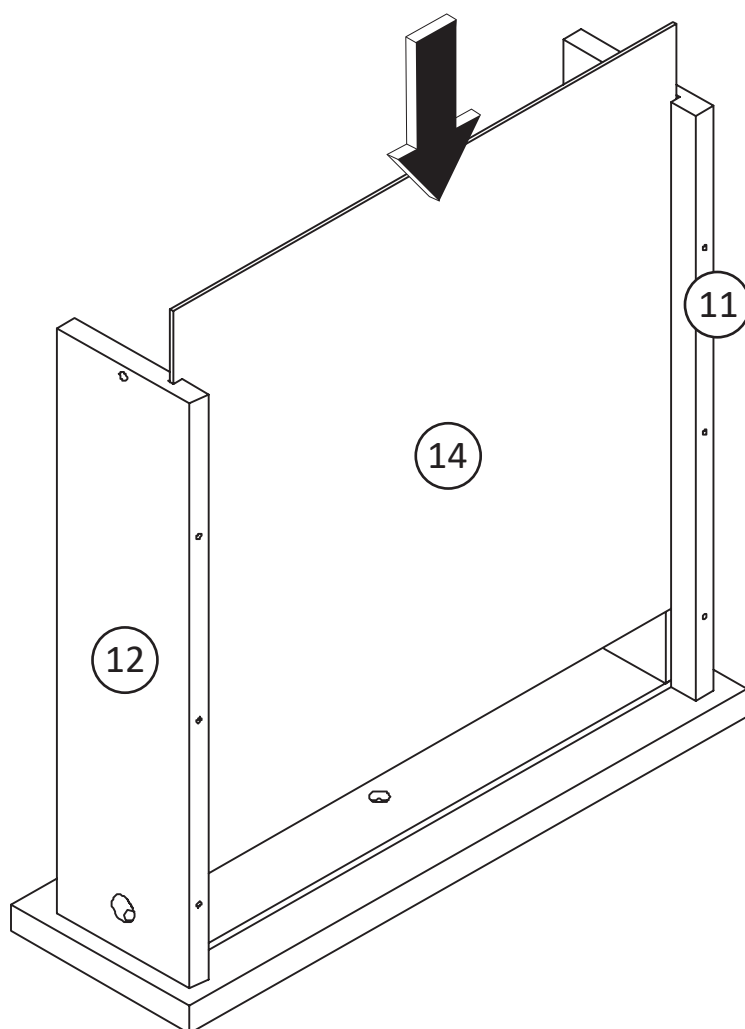

Step 18

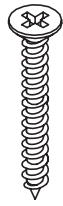
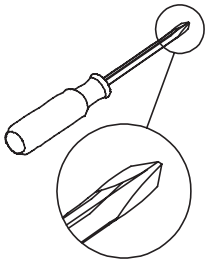

x2
TPK0008

Attach panel 13 and fix it using screw as shown.

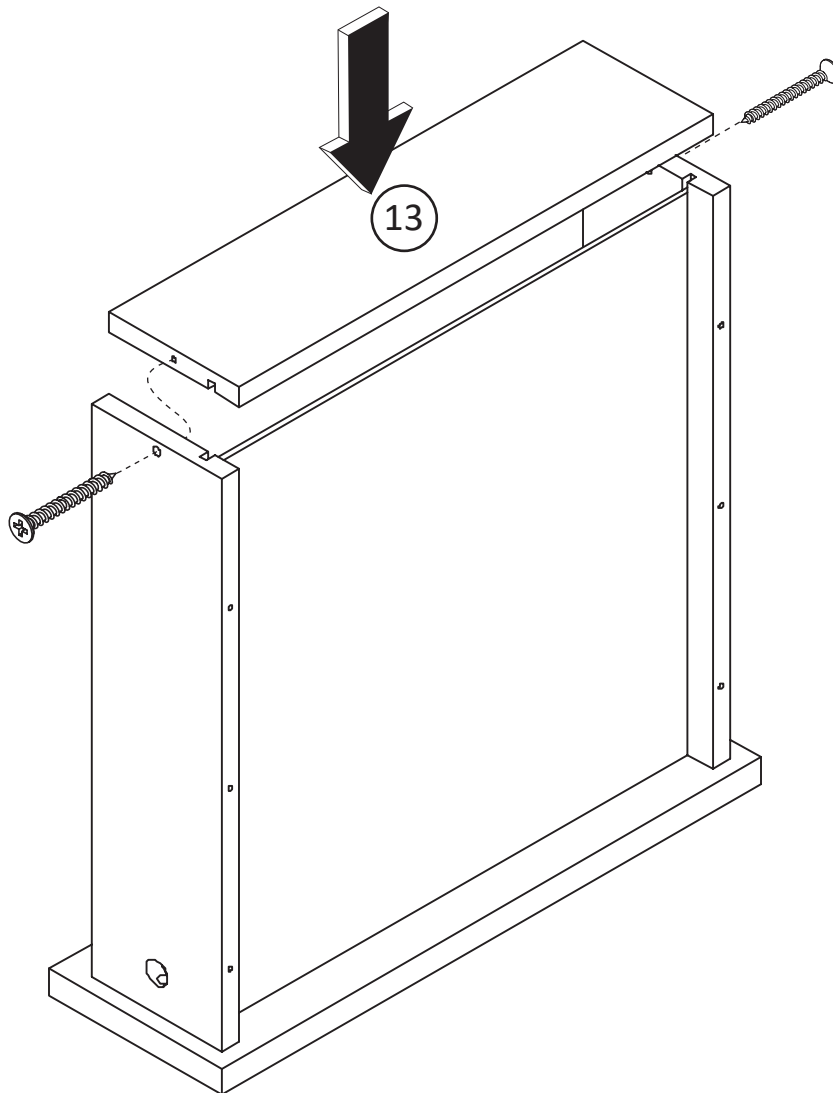

Step 19

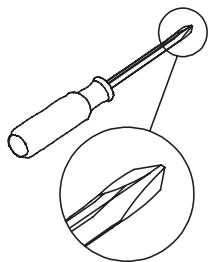

x6
TPK0007

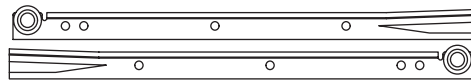

x1
TPK1004

Attach the slides (DL & DR) as shown.

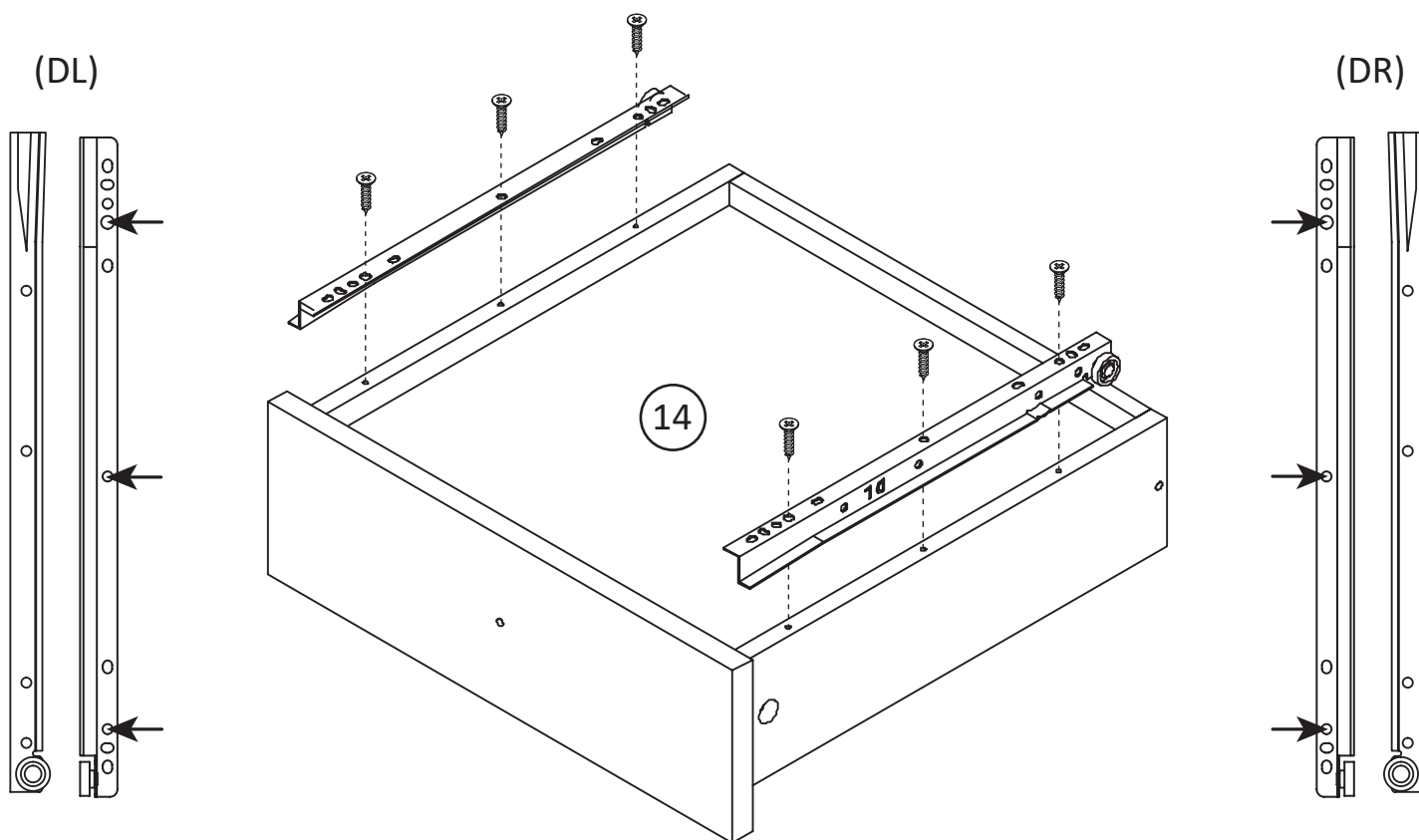

Step 20

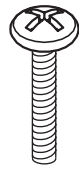
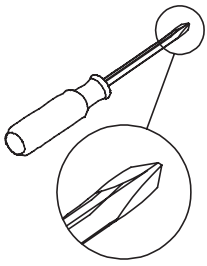

x1
TPK3006



x1
TPK3010

Fix the handle using provided screw.

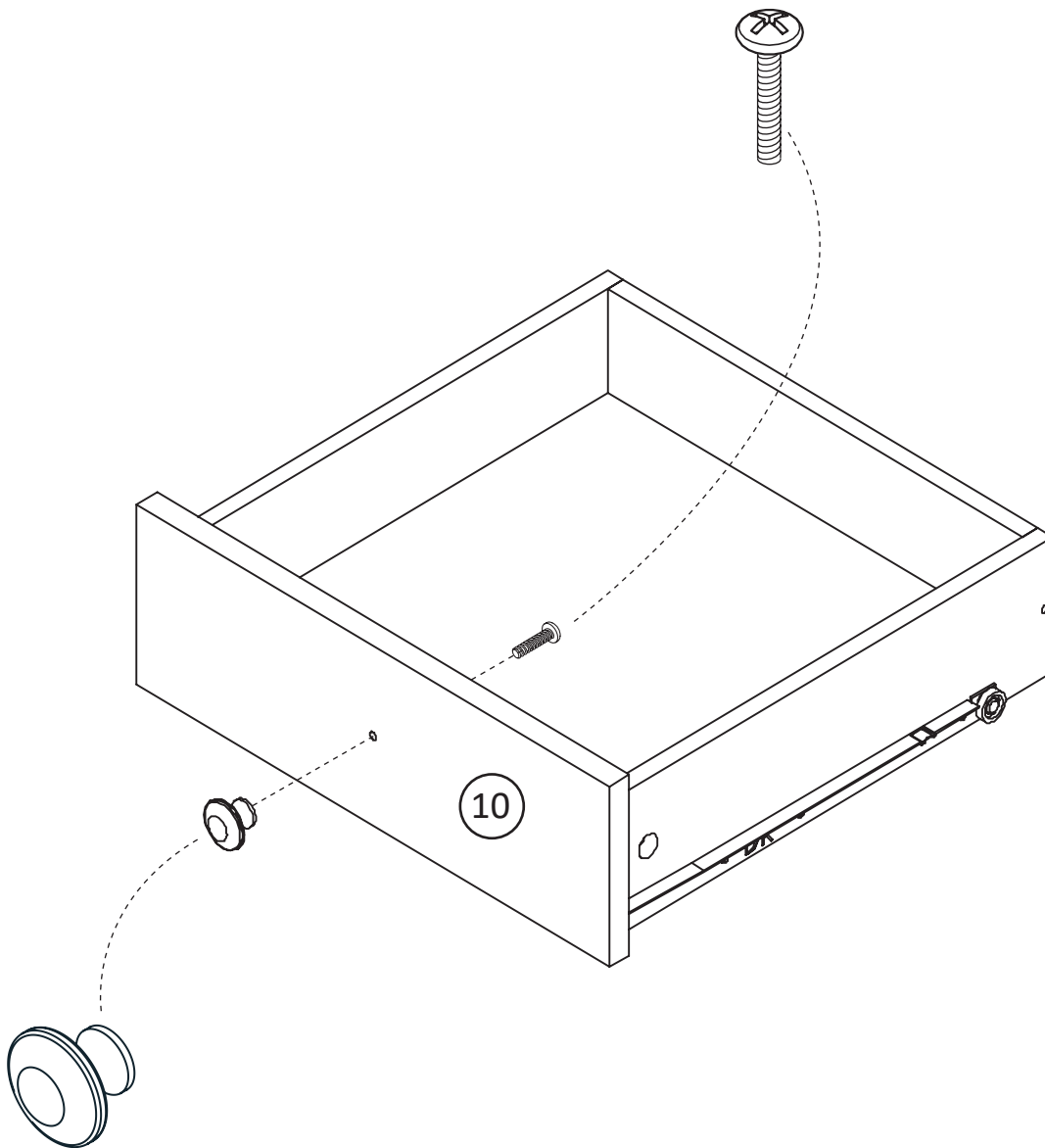

Step 21

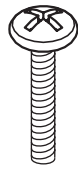
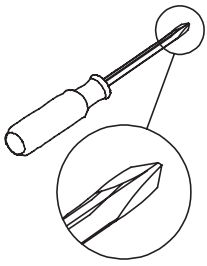

x1
TPK3006

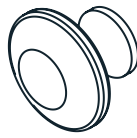

x1
TPK3010



x20
TPK0006

Fix the handle using provided screw.

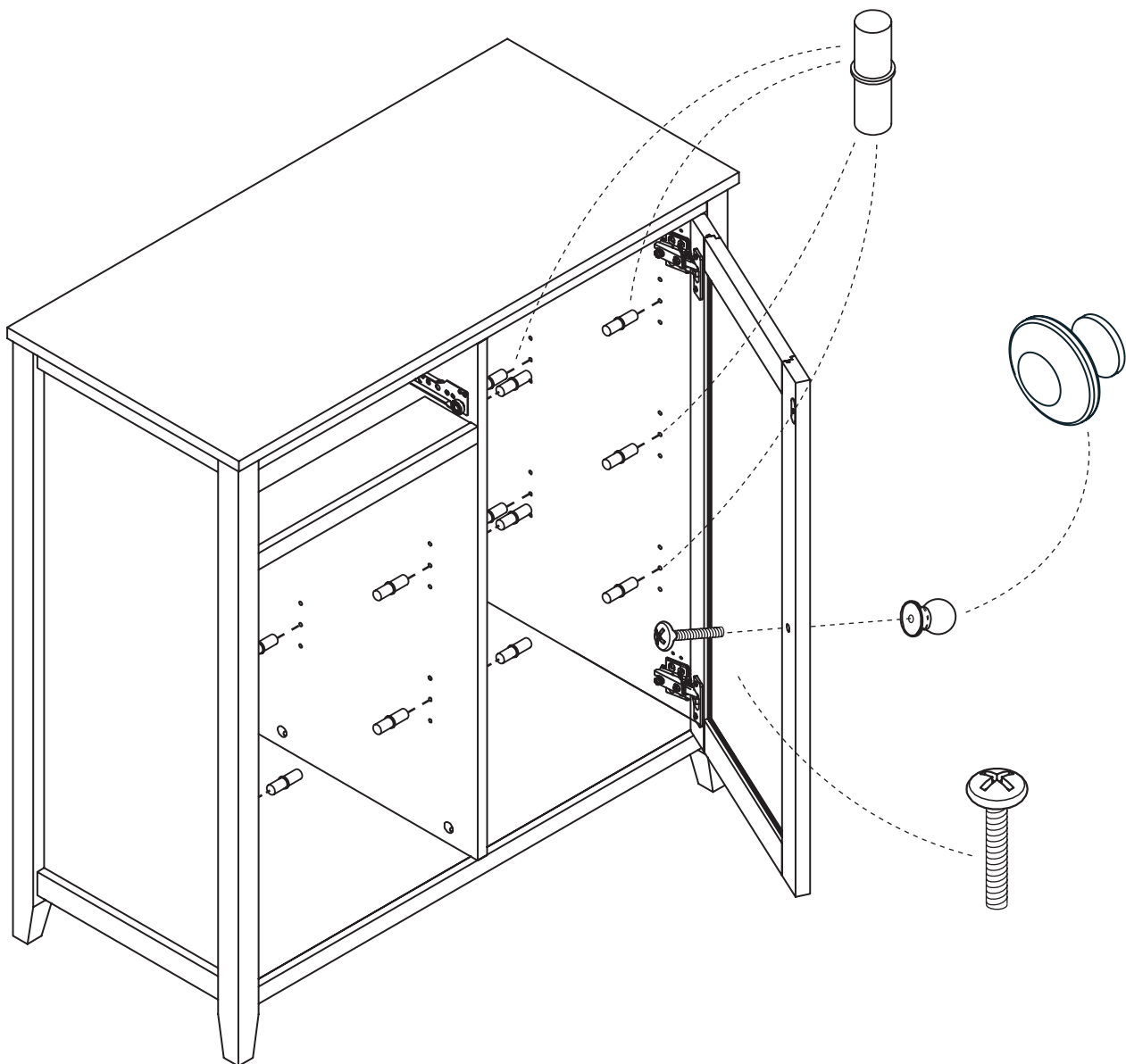

Step 22

Carefully attach the drawer to the carcass.

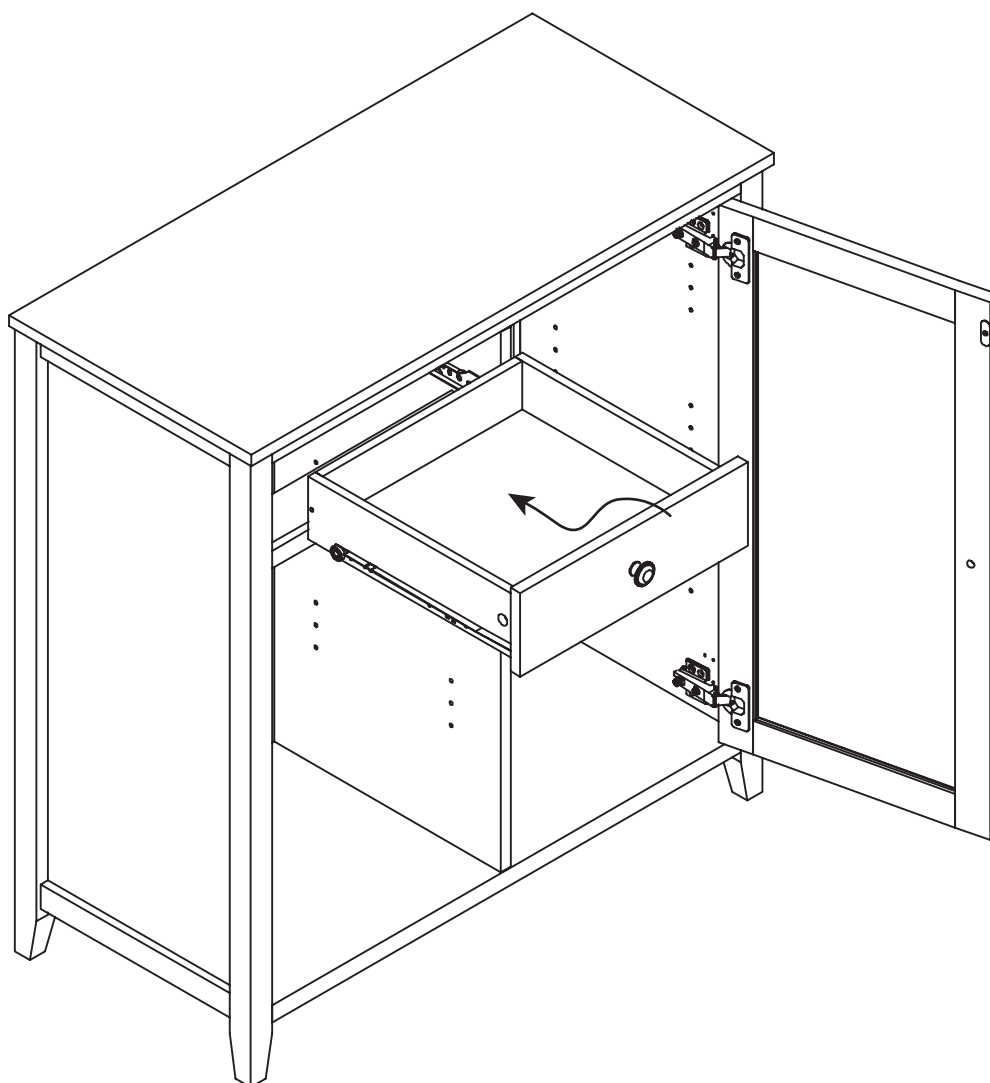

Step 23

Carefully attach the shelf to the carcass.

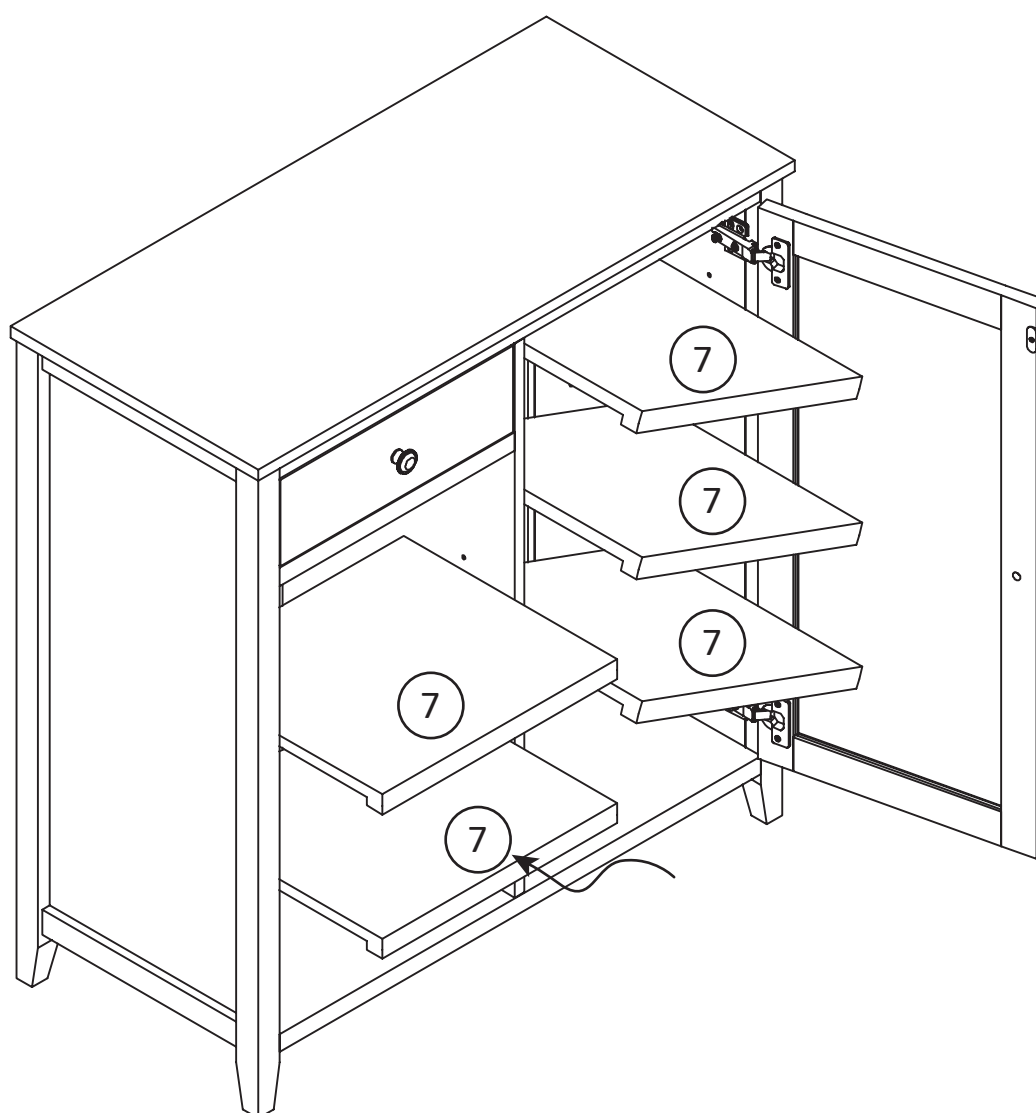

Maximum Loads

This unit has been designed to support the maximum loads shown. Exceeding these load limits could cause sagging, instability, product collapse, and/or serious injury.

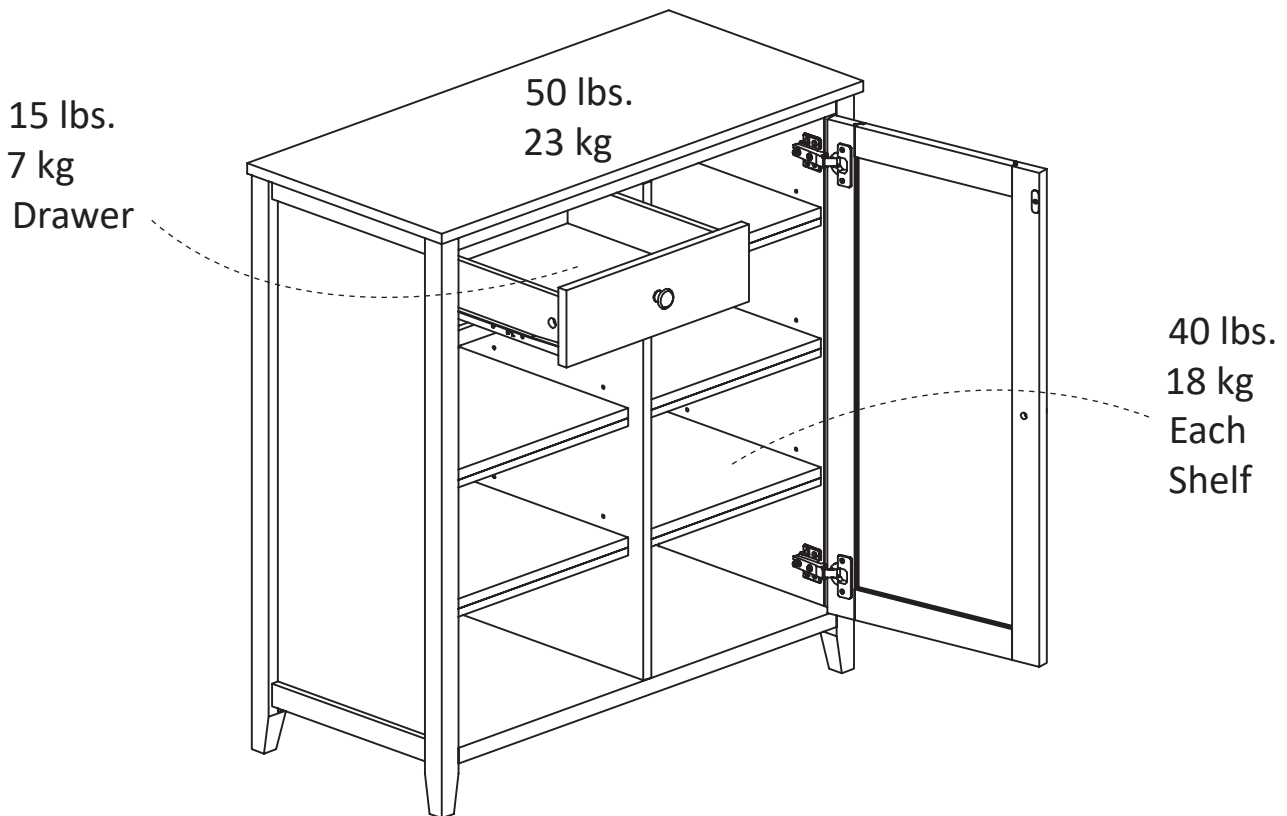

Warning: Risk of serious injury to person - do not place a television on this furniture. This furniture is not approved for use with a television.

Certificate of Confrmity

1. This certificate applies to Dorel Home Furnishings, Inc. product identified by this instruction manual.
2. This certificate applies to compliance of this product with the CPSC Ban on Lead-Containing Paint (16 CFR 1303).
3. This product is distributed by: Dorel Home Furnishings, Inc.
410 East First Street South,
Wright City, MO 63390
636-745-3351
4. Site of Manufacturer: Muar, Malaysia.
5. See front page of instruction manual for date of manufacturer.

Register your product to receive the following:



- * New trend details -sneak peek on what's new
- * Surveys -have a voice within our community
- * Exclusive deals and discount codes
- * Quick and easy replacement part service

To register your product, visit Ameriwoodhome.com

5 Star Rating



Visit your local retailer's website, rate your purchased product and leave us some feedback!

We would like to extend a big "Thank You" to all of our customers for taking the time to assemble this Ameriwood Home product, and to give us your valuable feedback

*Thank
You!*

Cubierta Delantera

Este libro de instrucciones contiene información IMPORTANTE de seguridad. Por favor lea y manténgalo para referencia en el futuro. No Regrese este producto! Comuníquese con nuestro amistoso equipo de servicio al cliente para obtener ayuda.

Llámenos al: 1-800-489-3351 (Gratis) Lunes - Viernes 9am - 5pm CST

Visitar: www.ameriwoodhome.com

PRECAUCION

Este mueble puede volcarse y causar graves heridas y/o muerte.

Anclar el mueble a un poste de madera en la pared (si esto se requiere).

No Permita que los niños monten el mueble.

Mantenga los artículos más pesados en los cajones de abajo.

Consejos Útiles (página 2)

- Abra su artículo en el área donde usted planea utilizarlo para evitar levantar y moverlo menos
- Identificar, ordenar y contar las piezas antes de intentar ensamblar
- Las clavijas de compresión se golpean con un martillo
- Las diapositivas están marcadas con una R (derecha) y L (izquierda) para la colocación correcta
- Asegúrese de que siempre este el punto localizado en la parte superior de bloqueador de leva este volteado hacia borde exterior
- Utilizar todos los clavos para el panel de atrás y distribuirlos por igual
- El panel de atrás debe utilizarse para asegurarse de que la unidad quede fija y firme
- No use químicos fuertes ni limpiadores abrasivos en este artículo
- Nunca empuje, tire ni arrastre los muebles

Antes de Que Empieces (página 3)

- Lea cuidadosamente cada paso y siga el orden correcto

- Separar y contar todas sus piezas y hardware

- Dése suficiente espacio para el proceso de ensamble

- Tenga las siguientes herramientas: destornillador de cabeza plana, #2 cabeza Phillips

Destornillador y martillo

- Precaución: Si usa un taladro electrónico o un destornillador eléctrico para atornillar, por favor asegúrese que deje de atornillar cuando el tornillo este apretado. Fallar hacer esto puede causar barrer el tornillo

Sistema de fijar el bloqueo de leva (página 3)

Este sistema de fijar el bloqueo de leva sera usado en todo el proceso ensamble

Identificación de la Junta (página 4)

Tamaño no real

Identificación de la Junta (página 5)

Tamaño no real

Lista de (página 6)

Tamaño real

Lista de (página 7)

Tamaño no real

Página 8

Paso 1: inserte correctamente el bloqueo de leva y la clavija.

Página 9

Paso 2 - Deslice (CL), posición del tornillo en el panel número 3. Deslice (CR), posición del tornillo en el panel número 4.

Página 10

Paso 3 - Inserte correctamente el bloqueo de leva y la clavija. Fije el kit antivuelco como se muestra. No apriete completamente aún en este paso.

Página 11

Paso 4 - Conecte el panel 5 al panel 1 como se muestra. Asegúrese de que el borde con el perfil hacia arriba. Fije usando el tornillo como se muestra.

Importante!, Por favor, asegúrese de más grande Agujero orientado al exterior.

Página 12

Paso 5 - Acople el panel 7 a los paneles 3 y 4. Luego apriete completamente el bloqueo de leva. Perfil debe estar orientado hacia afuera.

Página 13

Paso 6 - A continuación, coloque el panel 1 como se muestra. Asegúrese de que el borde con el perfil hacia arriba. Luego apriete completamente el bloqueo de la leva.

Página 14

Paso 7 - Fije el panel 6 al panel 2 como se muestra. Asegúrese de que el borde con el perfil hacia arriba. Fije usando el tornillo como se muestra.

Página 15

Paso 8: a continuación, coloque el panel 2 como se muestra. Asegúrese de que el borde con el perfil hacia arriba. Fije usando el tornillo como se muestra.

Página 16

Paso 9 - Antes de colocar el panel 15, asegúrese de dar vuelta la carcasa. Tenga cuidado, el suelo debe limpiarse y extenderse con un paño suave.

Unir el panel 15, este panel es parte de la estabilidad de la construcción. Por favor asegúrese de esquina a esquina en la misma dimensión. Extiende uniformemente las uñas de hierro.

Página 17

Para mampostería, hormigón u otros materiales de pared:

Consulte con su ferretería local para anclajes apropiados para fijar firmemente el soporte de seguridad.

IMPORTANTE: ESTA UNIDAD DEBE SER ASEGURADA A LA PARED PARA AYUDAR.

SIGA ESTAS INSTRUCCIONES PARA INSTALAR EL SOPORTE DE SEGURIDAD ANTI-TIPPING

PROPORCIONADO CON ESTE PRODUCTO.

ADVERTENCIA

Pueden ocurrir lesiones de aplastamiento graves o mortales desde el extremo del mueble. Para evitar que se vuelque:

- * Instale la punta sobre la sujeción provista
- * Coloque los artículos más pesados en los cajones más bajos
- * A menos que esté específicamente diseñado para acomodar, no coloque televisores u otros objetos pesados en la parte superior de este producto
- * Nunca permita que los niños se suban o cuelguen en cajones, puertas o estantes
- * Nunca abra más de un cajón a la vez

El uso de la punta sobre las restricciones sólo puede reducir, pero no eliminar el riesgo de vuelco

OPCIÓN 1: Acoplamiento en un perno de pared (método preferido)

Usando un buscador de vigas, ubique un perno en la pared. Coloque su unidad contra la pared, con el soporte de seguridad alineado en este lugar.

Para facilitar la conducción del tornillo, puede perforar un agujero piloto de 1/8 "de diámetro (3 mm) a través de la seguridad abrazadera en el espárrago.

Introduzca el tornillo a través del soporte de seguridad en el perno de pared. Apriete el tornillo que no estaba completamente apretado en el paso 5.

OPCIÓN 2: Accesorio en paneles de yeso

Localice su unidad donde se desee en una pared y marque la pared a través del soporte de seguridad, luego mueva su unidad a un lado.

Perfore un orificio de 3/16 "de diámetro (5 mm) en la pared. Toque el ancla de pared en el agujero hasta que quede al ras. Mueva su unidad a la ubicación y sujete el soporte de pared al ancla de pared con el tornillo. Apriete el tornillo que no estaba completamente apretado en el paso 5.

Página 18

Paso 11 - Inserte correctamente el bloqueo de leva.

Página 19

Paso 12: Acople el panel 10, 11 y 14 a los paneles 8 y 9. Apriete completamente el bloqueo de la leva.

Página 20

Paso 13: fije el panel 13 por la ranura en la ranura de los paneles 10 y 11.

Página 21

Paso 14 - Instale el panel 12 y fíjelo usando el tornillo como se muestra.

Página 22

Paso 15 - Fije la manija usando el tornillo provisto.

Página 23

Paso 16 - Adjunte las diapositivas (DL y DR) como se muestra.

Página 24

Paso 17 - Acople con cuidado el cajón a la carcasa.

Página 25**CARGA MAXIMA**

Esta unidad ha sido diseñada para soportar la carga máxima anotada. El exceder estos límites puede causar inestabilidad, colapsarse y/o causar serias lesiones.

ADVERTENCIA: Riesgo de lesiones a las personas - no coloque un televisor sobre muebles.

Este mueble no está aprobado para su uso con un televisor.

Página 26

Registre su producto para recibir lo siguiente:

- * Nuevos detalles sobre las tendencias - Sneek echa un vistazo a lo nuevo
 - * Encuestas - tener una voz dentro de nuestra comunidad
 - * Ofertas exclusivas y códigos de descuento
- Servicio de piezas de repuesto rápido y fácil

Para registrar su producto, visite Ameriwoodhome.com

5 estrellas

Visite el sitio web de su distribuidor local, califique su producto comprado y déjenos algunos comentarios!

Nos gustaría extender un gran "Gracias" a todos nuestros clientes por tomarse el tiempo para montar este producto Ameriwood Home, y para darnos sus valiosos comentarios
Gracias!

capot avant

Ce livret d'instructions contient d'importantes informations de sécurité. S'il vous plaît lire et conserver pour référence ultérieure.

Ne pas retourner ce produit! Contactez notre équipe de service à la clientèle amical pour aider.

Appel: 1-800-489-3351 (gratuit) Lundi - Vendredi 9am - 5pm CST

Visite: www.ameriwoodhome.com

MISE EN GARDE

Ce mobilier peut basculer et causer des blessures graves et / ou la mort.

Ancrer les meubles à un poteau en bois sur le mur (si cela est nécessaire).

Ne laissez pas les enfants monter l'armoire.

Gardez les articles plus lourds dans les tiroirs ci-dessous.

Conseil (page 2)

- Ouvrez votre article dans la zone où vous prévoyez de l'utiliser pour éviter de soulever et déplacer moins
- Identifier, trier et compter les pièces avant de monter
- bouchons de compression sont frappés avec un marteau
- Les lames sont marqués par un R (droite) et L (à gauche) pour le positionnement correct
- Assurez-vous toujours ce point, je Aviana sur le dessus de la came de blocage ce bord extérieur volteadohacia
- Utilisez tous les clous du panneau arrière et les distribuer également
- Le panneau arrière doit être utilisé pour faire en sorte que l'unité est fixe et ferme
- Ne pas utiliser de produits chimiques ou de produits abrasifs sur cet article
- Ne jamais pousser, tirer ou meubles de glisser

Avant de commencer (page 3)

- Lire attentivement chaque étape et suivre l'ordre
- separate et compter toutes les pièces et matériel
- Dése un espace suffisant pour le processus d'assemblage
- Soyez les outils suivants: tournevis Phillips n ° 2 tête
Tournevis et un marteau
- Precaución: Si vous utilisez une perceuse électronique ou un tournevis électrique à vis, s'il vous plaît faire arrêter le vissage lorsque le tonillos ce serré. Le non-respect cela peut provoquer balayer la vis

Système de régler le verrou de came (page 3)

Ce système de fixation du verrou de came sera utilisé tout au long du processus d'assemblage

Identification du Conseil (page 4)

pas la taille réelle

Identification du Conseil (page 5)

pas la taille réelle

Liste (Page 6)

taille réelle

Liste (Page 7)

pas la taille réelle

Page 8

Étape 1 - Insérez correctement le verrou à came et le goujon.

Page 9

Étape 2 - Faites glisser la vis (CL) sur le panneau numéro 3. Faites glisser la vis (CR) sur le panneau 4.

Page 10

Étape 3 - Insérez correctement le verrou à came et le goujon. Fixez le kit anti-basculement comme indiqué. Ne serrez pas encore complètement dans cette étape.

Page 11

Étape 4 - Fixez le panneau 5 au panneau 1 comme indiqué. Assurez-vous que le bord avec le profil est orienté vers le haut. Fixez à l'aide de la vis comme indiqué.
Important!, S'il vous plaît assurez-vous plus grand trou face à l'extérieur.

Page 12

Étape 5 - Fixez le panneau 7 aux panneaux 3 et 4. Serrez ensuite complètement le verrou de came. Le profil doit faire face à l'extérieur.

Page 13

Étape 6 - Ensuite, attachez le panneau 1 comme indiqué. Assurez-vous que le bord avec le profil est orienté vers le haut. Serrez ensuite complètement le verrou de came.

Page 14

Étape 7 - Fixez le panneau 6 au panneau 2 comme indiqué. Assurez-vous que le bord avec le profil est orienté vers le haut. Fixez à l'aide de la vis comme indiqué.

Page 15

Étape 8 - Ensuite, attachez le panneau 2 comme indiqué. Assurez-vous que le bord avec le profil est orienté vers le haut. Fixez à l'aide de la vis comme indiqué.

Page 16

Étape 9 - Avant de fixer le panneau 15, assurez-vous de retourner la carcasse. Attention, le sol doit être nettoyé et étalé avec un chiffon doux.
Fixez le panneau 15, ce panneau fait partie de la stabilité de la construction. Veuillez vous assurer que les angles sont identiques. Étaler uniformément les clous de fer.

Page 17

Maçonnerie, béton ou d'autres matériaux de paroi:
Vérifiez auprès de votre magasin local de matériel pour les ancrages appropriés pour fixer fermement le support de sécurité.

IMPORTANT: CET APPAREIL DOIT ÊTRE FIXÉ AU MUR POUR AIDER.
CES INSTRUCTIONS POUR INSTALLER LE SUPPORT antibasculant DE SÉCURITÉ
Avec ce produit.

AVERTISSEMENT

Blessures par écrasement graves, voire mortelles, la fin du gouvernement peut se produire. Pour éviter le basculement:

- * Fixer l'extrémité prévue sur le serrage
- * Placez les articles plus lourds dans les tiroirs inférieurs
- * À moins que vous spécifiquement Prédisposition pour ne pas mettre les téléviseurs ou d'autres objets lourds sur ce produit
- * Ne jamais laisser les enfants grimper ou de se pendre tiroirs, portes ou étagères
- * Ne jamais ouvrir plus d'un tiroir à la fois

En utilisant la pointe des restrictions ne peut réduire mais pas éliminer le risque de retournement

OPTION 1: Le couplage d'un poteau de mur (préféré)

L'utilisation d'un détecteur de montants, localiser un goujon dans le mur. Placez votre appareil contre le mur, avoir obtenu le soutien ici.
Pour faciliter l'entraînement de la vis, percer un trou pilote peut 1/8 « de diamètre (3 mm) à travers le boulon de serrage de sécurité.
Insérez la vis à travers la paroi de goupille de sécurité du support. Serrer la vis qui n'a pas été complètement serré à l'étape 5.

OPTION 2: Cloisons sèches accessoires

Localisez votre endroit désiré dans un mur et mur marque à travers le support de sécurité, puis Écarter l'unité.
Forer un diamètre de 3/16 »(5 mm) dans le mur. Appuyez sur l'ancrage mural dans le trou jusqu'à ce qu'il affleure. Déplacez votre lecteur à l'emplacement et fixez le support mural sur la fixation murale avec vis. Serrer la vis qui n'a pas été complètement serré à l'étape 5.

Page 18

Étape 11 - Insérez correctement le verrou à came.

Page 19

Étape 12 - Fixez les panneaux 10, 11 et 14 aux panneaux 8 et 9. Serrez à fond le verrou de came.

Page 20

Étape 13 - Fixez le panneau 13 par la fente dans la rainure des panneaux 10 et 11.

Page 21

Étape 14 - Fixez le panneau 12 et fixez-le avec la vis comme indiqué.

Page 22

Étape 15 - Fixez la poignée à l'aide de la vis fournie.

Page 23

Étape 16 - Fixez les diapositives (DL & DR) comme indiqué.

Page 24

Étape 17 - Fixez soigneusement le tiroir à la carcasse.

Page 25**MAXIMUM DE CHARGE**

Cet appareil est conçu pour supporter la charge maximale enregistrée. Le dépassement de ces limites peut provoquer l'instabilité, l'effondrement et / ou causer des blessures graves.

AVERTISSEMENT: Risque de blessures aux personnes - ne placez pas la télévision sur les meubles.

Ce mobilier est pas approuvé pour une utilisation avec une télévision.

Page 26

Enregistrez votre produit pour recevoir les éléments suivants:

- * De nouveaux détails sur les tendances - Sneek vérifier la nouvelle
- * Sondages - ont une voix dans notre communauté
- * Offres exclusives et des codes de réduction
- Service de pièces de rechange rapide et facile

Pour enregistrer votre produit, visitez Ameriwoodhome.com

5 étoiles

Visitez le site Web de votre distributeur local, classez votre produit acheté et laissez des commentaires!

Nous aimerions étendre un grand "Merci" à tous nos clients pour prendre le temps de rassembler ce produit Ameriwood Home et de nous faire part de vos précieux commentaires

Merci!



THANK YOU for your business.



Your feedback and 5-star review is important to us!



If you are happy with this product, please review on the site you purchased it from.



If your product has issues, please contact us so that we can fix them.

Please note, we do not have control over how shipping carriers treat our products and could cause damage to your order. If your product is damaged, please contact us for help.

**1-800-489-3351 • Customer.service@dorel.com
Customer Service Hours: 9am - 5pm Central Time (CST)
Monday through Friday**

